

LA-5794-M

Manual

G.A. Schreiber

UC-15 MST-12
Reporting Date: December 1974
Issued: March 1975

C 3

Dec. 1 - Dec. 5, 1986

CIC-14 REPORT COLLECTION
**REPRODUCTION
COPY**

A Guide to Gamma-Ray Assay for Nuclear Material Accountability

by

T. D. Reilly
J. L. Parker

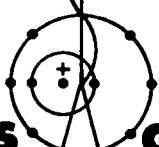

los alamos
scientific laboratory

of the University of California

LOS ALAMOS, NEW MEXICO 87544

An Affirmative Action/Equal Opportunity Employer



UNITED STATES
ENERGY RESEARCH AND DEVELOPMENT ADMINISTRATION
CONTRACT W-7405-ENG. 36

In the interest of prompt distribution, this manual was not edited by the Technical Information staff.

Work supported by U. S. Energy Research and Development Administration, Division of Safeguards and Security.

Printed in the United States of America. Available from
National Technical Information Service
U.S. Department of Commerce
5285 Port Royal Road
Springfield, VA 22151
Price: Printed Copy \$5.45 Microfiche \$2.25

This report was prepared as an account of work sponsored by the United States Government. Neither the United States nor the United States Energy Research and Development Administration, nor any of their employees, nor any of their contractors, subcontractors, or their employees, makes any warranty, express or implied, or assumes any legal liability or responsibility for the accuracy, completeness, or usefulness of any information, apparatus, product, or process disclosed, or represents that its use would not infringe privately owned rights.

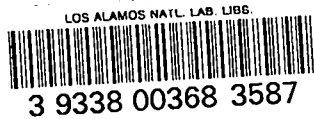

CONTENTS

Abstract 1

1. Introduction 1

 1.1 Scope of Report 1

 1.2 General Principles of Gamma-Ray Assay 1

2. Gamma-Ray Signatures, Spectra, and Detectors 3

 2.1 Signatures 3

 2.2 Detectors 3

3. Peak Stripping and Background Subtraction 7

 3.1 Introduction 7

 3.2 Straightline Subtraction Techniques for
 Well Resolved Single Peaks 7

 3.3 Multiple Peaks 9

4. Detector Efficiency and the Inverse Square Law 10

5. Attenuation Correction Factors 13

 5.1 General Attenuation Considerations 13

 5.2 Attenuation Correction Factor Expressions 14

 5.3 Transmission-Corrected Gamma-Ray Assay 15

 5.4 Differential Absorption Correction 17

 5.5 Other Attenuation Corrections 20

6. Rate-Related Counting Losses 22

 6.1 Nature of the Problems: Methods of
 Minimization 22

 6.2 Constant Rate Pulser Corrections 22

 6.3 Gamma-Ray Source Normalization 23

 6.4 Detector Generated Pulser 24

7. Assay Procedures 25

 7.1 Transmission-Corrected Segmented Scanning 25

 7.2 Variations of Transmission-Correction Procedures 26

 7.3 Differential Absorption Methods 27

 7.4 NaI Detector Procedures 27

8. Types of Assay Systems 29

 8.1 Computer-Based Ge(Li) System 29

 8.2 MCA-Based Ge(Li) System 29

 8.3 SCA-Based System 29

9.	Standards	31
10.	Packaging	36
11.	Material Categories -- Precision and Accuracy	38
Appendix A. Plutonium Isotopic Distributions by Gamma-Ray Spectroscopy		
		A-1
1.	Background	A-1
2.	Current Status	A-1
3.	Generalized Method Applicable to Scrap and Waste	A-1
3.1	Assumptions and Signatures	A-1
3.1.1	Necessary Assumptions	A-1
3.1.2	Useful Gamma Rays	A-2
3.2	General Ideas and Technical Considerations	A-2
3.2.1	Isotopic Ratios are Quantities Measured	A-2
3.2.2	Relative Detection Efficiency	A-3
3.2.3	Americium Corrections	A-3
3.2.4	Rate-Related Errors	A-3
3.2.5	Peak Area Determinations	A-4
3.2.6	Isotopic Verification	A-4
3.3	Determination of Isotopic Ratios	A-4
3.3.1	Ratio of $^{241}\text{Pu}/^{239}\text{Pu}$	A-4
3.3.2	Ratio of $^{238}\text{Pu}/^{241}\text{Pu}$	A-5
3.3.3	Ratio of $^{240}\text{Pu}/^{239}\text{Pu}$	A-5
3.3.4	Ratio of $^{241}\text{Am}/^{239}\text{Pu}$	A-5
3.4	Preliminary Results	A-6
Appendix B. Differential Absorption Attenuation Correction Factor		
		B-1
1.	Small Scrap Can	B-1
2.	Large Waste Drum	B-2
Appendix C. Assay Expressions for a Transmission- Corrected Segmented Scan Gamma Assay Measurement		
		C-1

A GUIDE TO GAMMA-RAY ASSAY FOR NUCLEAR MATERIAL ACCOUNTABILITY

by

T. D. Reilly and J. L. Parker

ABSTRACT

This report discusses the fundamental principles of gamma-ray assay for nuclear material accountability.

1. INTRODUCTION

1.1 Scope of Report

The subject of this report is the measurement of uranium- and plutonium-bearing materials using methods of gamma-ray spectroscopy. It is meant to be a guide for a knowledgeable person and assumes the reader has at least a basic understanding of such matters as half-life and decay rate, gamma-ray interactions with matter (attenuation), detectors and detection processes, and the use of gamma spectroscopy equipment (detectors, multichannel pulse-height analyzers and associated electronics). For background in these subjects consult the listed references.^{1.1, 1.2, 1.3} It cannot be too strongly emphasized that the most important ingredient in implementing and supervising any gamma-ray assay system is a capable and well trained technical person. Gamma-ray measurements can yield very accurate information for uranium and plutonium accountability but only if performed and interpreted properly.

1.2 General Principles of Gamma-Ray Assay

The basis for gamma assay is that many of the isotopes of uranium and plutonium emit gamma rays whose energy and intensity are uniquely characteristic of the decaying isotope. For example, one gram of ^{235}U emits approximately 4.3×10^4 , 185.7-

keV gamma rays per second. The general procedure for gamma-ray assay is outlined in Eq. (1.1).

$$M = \frac{CR \cdot CF}{K}, \quad (1.1)$$

where

M = mass of isotope of interest,
CR = measured count rate from signature of isotope,
CF = correction factor for sample attenuation,
K = calibration factor (corrected counts per gram).

The calibration factor (K) is determined by measuring a known standard. This can be represented by inverting Eq. (1.1).

$$K = \frac{CR_s \cdot CF_s}{M_s}, \quad (1.2)$$

where

M_s = known mass of emitting isotope in standard,
 CR_s = measured count rate from standard,
 CF_s = correction factor for attenuation in standard.

The standard essentially provides a measurement of the detector efficiency, the specific activity of the signature of interest, and the effects of sample geometry (size, shape, and sample-to-detector distance). These equations assume the standard is the

same shape and is measured in the same position as the unknowns. The basic idea may be stated simply, but the assayist needs a good understanding of the many factors involved in order to apply them correctly:

(1) *Gamma-Ray Signatures*: the energies and intensities of the relevant gamma rays place fundamental restrictions on the sensitivity, precision, and accuracy of any assay.

(2) *Detectors and Gamma-Ray Spectra*: an understanding of detector properties and the general appearance of pulse-height spectra is necessary to interpret the measured data.

(3) *Peak Stripping and Background Subtraction*: these are the basic procedures for extracting information from the measured spectrum.

(4) *Detector Efficiency and the Inverse Square Law*

(5) *Gamma-Ray Attenuation and the Attenuation Correction Factor*: the key to accurate gamma assay.

(6) *System Count Rate Limitations*

(7) *Sample Scan Procedures*

(8) *Types of Gamma-Assay Systems*

These subjects are all treated in some detail in this report.

REFERENCES

1.1 R. H. Augustson and T. D. Reilly, "Fundamentals of Passive Nondestructive Assay of Fissionable Material," Los Alamos Scientific Laboratory report LA-5651-M, 1974.

1.2 F. Adams and R. Dams, *Applied Gamma-Ray Spectrometry*, (Pergamon Press, Inc., NY, 1970). This book contains a wealth of information on gamma-ray spectrometry. The first three chapters cover gamma-ray emission and interaction, and the properties and characteristics of scintillation and semiconductor detectors. Chapter 5 deals with associated detector instrumentation. The appendices include many useful tables, graphs, and spectra [e.g., x-ray absorption edges and emission energies (table); NaI gamma-ray spectra (over 250 actual pulse-height spectra); Ge(Li) spectra (over 200); intrinsic efficiencies of NaI detectors (tables); and tables of gamma-ray energies]. This is a useful reference for the gamma assayist.

1.3 R. D. Evans, *The Atomic Nucleus*, (McGraw-Hill Book Company, Inc., 1955). Though old, this is one of the best texts on nuclear physics. Recommended chapters include: Chapter 15--Radioactive Decay, Chapters 23 through 25--Interaction of Electromagnetic Radiation with Matter, Chapter 26--Statistical Fluctuations in Nuclear Processes, and Chapter 28--Applications of Poisson Statistics to Some Instruments Used in Nuclear Physics.

2. GAMMA-RAY SIGNATURES, SPECTRA, AND DETECTORS

2.1 Signatures

The major gamma-ray signatures for uranium and plutonium are listed in Table 2.1. References 2.1-2.4 at the end of this chapter contain more complete tabulations of gamma-ray data. Both major fissile isotopes have moderately intense, interference-free signatures: ^{235}U -185.7 keV; ^{239}Pu -413.7 keV. Most of this report will deal with the measurement of uranium or plutonium using these gamma rays. Appendix 1 contains a brief discussion of the measurement of other plutonium isotopes. Figures 2.1 and 2.2 show complete Ge(Li) spectra of uranium and plutonium, respectively. Figure 2.3 is an expanded view of the 414-keV region of plutonium.

2.2 Detectors

The major detectors for nuclear materials assay are NaI(Tl) scintillation detectors and Ge(Li) semiconductor detectors. NaI has the advantage of

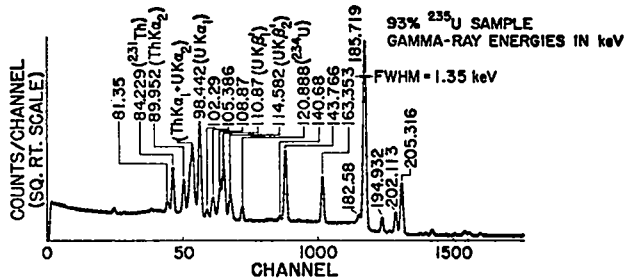

Fig. 2.1. Characteristic gamma rays of ^{235}U . This spectrum was measured with a high resolution Ge(Li) detector.

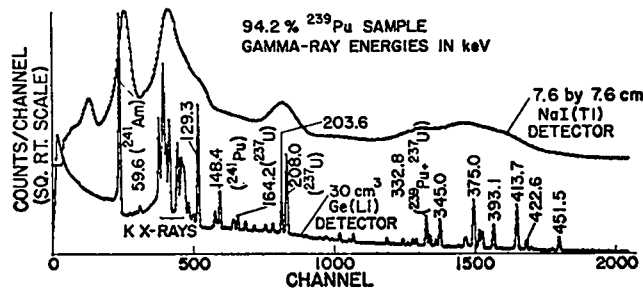

Fig. 2.2. Comparison of plutonium gamma-ray spectra from 30-cm^3 Ge(Li) detector and $7.6\text{-by } 7.6\text{-cm}$ NaI detector. Note the square root scale.

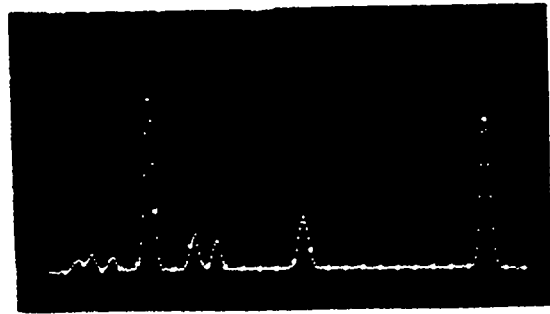

Fig. 2.3. Ge(Li) spectrum showing 414-keV region of plutonium spectrum in detail. The three highest peaks are 375.0, 393.0, and 413.7 keV, all from ^{239}Pu .

room temperature operation, economy and higher efficiency. Unfortunately, its resolution is clearly marginal for many assay situations. The 186-keV gamma from ^{235}U is usually resolved by NaI (Fig. 2.4) if there are no other significant gamma emitters in the sample. A good NaI will have a resolution of about 12% (22 keV) FWHM at 186 keV. Any intense gamma ray within about 70 keV (3 FWHM) of 186 keV can be expected to interfere directly with the ^{235}U photopeak. Higher energy gamma rays will interfere by producing a large Compton continuum under the photopeak. If high energy gammas exist with intensity much over $10\ \mu\text{Ci}$ per gram of ^{235}U , serious signal-to-background problems can be expected in the 186-keV region. For low-enriched uranium ($<1\%$ ^{235}U) the daughter product activity of ^{238}U (765 and 1001 keV) interferes quite severely with the NaI measurement of the 186-keV gamma ray. The NaI detector is not recommended for accurate measurements of low enriched uranium.

Due to its low resolution the NaI photopeak includes a significant number of scattered gamma rays caused by small angle (hence, small energy loss) Compton scatters within the sample. This can be described by a "buildup factor" (see Ref. 1.3, p. 732) which is difficult to compute and can greatly complicate the interpretation and measurement of sample attenuation. The magnitude of this effect can vary considerably depending on the sample density and composition. In contrast, the Ge(Li) detector suffers much less from this effect. The Ge(Li) photopeak can be assumed to contain only

TABLE 2.1

MAJOR GAMMA-RAY SIGNATURES FOR THE FISSIONABLE ISOTOPES

Isotope	Energy (keV)	Intensity (g-s) ⁻¹	Comments
²³⁵ U	185.72	4.3 x 10 ⁴	Only intense gamma ray. Resolved with NaI as well as Ge(Li). Useful for enrichment and quantitative measurements. Several much weaker peaks are seldom useful.
²³⁸ U	1001.10 766.40	1.0 x 10 ² 3.9 x 10 ¹	These actually arise from the ^{234m} Pa daughter of ²³⁸ U. After chemical separation about 100 days are required for the activity to come into equilibrium at the levels stated. Plutonium-238 gives rise to the same 766.40-keV gamma and would produce interference in U-Pu mixtures. Useful for work with Ge(Li) or NaI.
²³⁸ Pu	766.40 152.77	1.5 x 10 ⁵ 6.5 x 10 ⁶	Most useful for quantitative assay. Ge(Li) or NaI. Useful for isotopic determinations with Ge(Li).
²³⁹ Pu	413.69	3.4 x 10 ⁴	The 413.69 usually provides the basis for Ge(Li) assays. The 413.69 plus the 375.02 and its weak neighbors form a complex upon which NaI assays are based.
²³⁹ Pu	129.28	1.4 x 10 ⁵	Useful for isotopic determinations with Ge(Li). Plutonium-239 has over 100 gamma rays, some of which are useful for careful work with Ge(Li).
²⁴⁰ Pu	--	--	Several weak gamma rays but all suffer bad interference from gammas of other isotopes. Requires very careful work with high-resolution detector to make use of any of them.
²⁴¹ Pu	207.98	2.0 x 10 ⁷	Actually from ²³⁷ U daughter and requires about 25 days after chemical separation to come into equilibrium at stated value. May also have a few percent interference from ²⁴¹ Am which emits same gamma. Nevertheless a good clean strong gamma useful with both NaI and Ge(Li).
	164.59	1.8 x 10 ⁶	Useful with Ge(Li). Also from ²³⁷ U.
	148.60	7.5 x 10 ⁶	Useful with Ge(Li). Direct from ²⁴¹ Pu.
²⁴¹ Am	59.54	4.6 x 10 ¹⁰	Very strong gamma but attenuation problems. Useful with Ge(Li) or NaI. Has several other <i>much</i> less intense gammas sometimes useful for Ge(Li) work.
²⁴² Pu	--	--	No useful gamma rays at all. Nature failed us at this point.

unscattered gamma rays plus a small contribution from Rayleigh scattering. This makes the interpretation of sample attenuation much more straightforward.

The 414-keV gamma ray from ²³⁹Pu is usually not resolved by NaI. The broad peak (300-450 keV) in Fig. 2.5 contains many gamma rays from ²³⁹Pu, ²⁴¹Pu (through its ²³⁷U daughter), and ²⁴¹Am. The major activities are from ²³⁹Pu (375 and 414 keV) and

²⁴¹Pu (332.3 keV). If the plutonium isotopic composition remains constant, this region can be used to measure ²³⁹Pu. For varying isotopic composition, it is possible to integrate the upper half of the peak (e.g., 375-450 keV) and minimize the varying interference from ²⁴¹Pu. With proper standards and adequate control NaI can be used for plutonium scrap and waste assay. Indeed, many of the systems in use at present are NaI.



Fig. 2.4. NaI spectrum of uranium (93% ^{235}U on left, 0.7% ^{235}U on right; 5.1- by 5.1-cm detector). The three major features (1 to r in the 93% spectrum) are ~ 100 keV (uranium K x rays), 143.8 keV (^{235}U), and 185.7 keV (^{235}U). For the 0.7% spectrum a cadmium filter was placed over the detector to reduce the x-ray peak. Note the large Compton background from higher energy ^{238}U daughter radiations in the 0.7% spectrum. The vertical scales are different on the two spectra.

FWHM?

Some guidelines can be given for choosing the proper size NaI detector. For most measurements of the 186-keV gamma ray of ^{235}U , a 2.5-cm-thick detector is recommended. This will absorb over 90% of the gamma rays of interest. Thicker detectors will just add background. With a signal-to-background much less than one, it can be shown that the optimum detector thickness is about 1.2 cm. The use of NaI for such counting situations is not recommended. For normal, lower background situations the 2.5-cm crystal is a more practical choice. At 414 keV detectors up to 13 cm thick may be used, but 8 cm is usually adequate (this will absorb nearly 70% of the gamma rays of interest).

The Ge(Li) detector is preferred for nuclear material assay because of its superior resolution (e.g., at 414 keV a good Ge(Li) will have a resolution of about 1.4 keV FWHM as compared to a good NaI with 40 keV FWHM). The obvious advantage is the ability to separate the peaks of interest from other neighboring gamma-ray peaks. For example, the broad peak in the NaI spectrum of Fig. 2.5 is resolved by Ge(Li) into many individual components. The 414-keV gamma ray is well resolved by even a medium quality Ge(Li). A less obvious advantage is that the full energy peak in a Ge(Li) spectrum is more nearly composed of unscattered gamma rays (there is little "buildup" under the peak). Due to

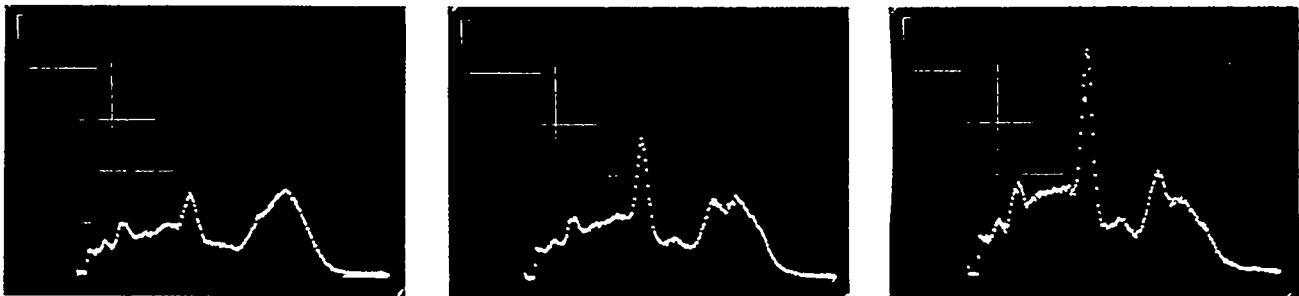

Fig. 2.5. NaI spectrum of plutonium (5.1- by 5.1-cm detector). Three different plutonium isotopics are shown: from 1 to r, ^{239}Pu , 94%, 87%, 75%; ^{241}Pu , 0.3%, 2.5%, 5%. The two major features of the spectrum are the 208-keV peak from ^{241}Pu (^{237}U) and the broad peak 333-414 keV from ^{239}Pu and ^{241}Pu . The low-energy side of this peak is due mostly to ^{241}Pu . A lead and cadmium filter is placed over the detector to reduce the ^{241}Am and x-ray activity. These pictures illustrate the ^{241}Pu interference to the 400-keV ^{239}Pu complex.

its high resolution even small angle Compton scatterings result in a secondary gamma which is outside the full energy peak. This is very important for bulk material assay since it simplifies the interpretation and evaluation of sample attenuation, the key factor in gamma-ray assay. In simplest terms the Ge(Li) detector provides a more unambiguous signal, and its use is preferred for nuclear material assay.

For most assay of bulk samples (e.g., scrap and waste) a Ge(Li) detector with the following performance specifications should be adequate:

FWHM at 1332 keV = 2.0 - 2.2 keV,

FWHM at 122 keV = 1.1 - 1.2 keV,

Eff at 1332 keV \approx 10%.

The resolution at 122 keV (^{57}Co) should be specified when ordering the detector since most gamma rays of interest for nuclear material assay are in the range 100-500 keV, and this is a more relevant specification. Larger detectors are available (eff \leq 25%); however, the gain in efficiency at 100-400 keV is much smaller than that at 1332 keV, and the added cost is usually not justified. The frontal area of these large detectors is often no greater than a well chosen 10% detector, and the added depth increases the low energy efficiency only slightly. This reflects the same consideration discussed above for NaI; a detector need be no more than 2-3 mean free paths thick to the highest energy gamma ray of interest. The low energy resolution can be improved considerably through the use of a cooled FET in the first stage of the detector preamp (e.g., large detectors are available with a resolution in the range 600-700 eV at 122 keV). This would usually be warranted only for very high resolution spectroscopy; e.g., plutonium isotopic measurement. It is not recommended for assays based on the 186-keV or 414-keV gammas alone. The detector mounting (cryostat and dewar) must be compatible with the required shielding and collimation and should be considered carefully when ordering a detector. More information on specifying Ge(Li) spectroscopy systems is provided in Regulatory Guide 5.9. ^{2.5} Large high purity germanium detectors are not yet available commercially and are not discussed here. Their use and required performance specifications would not differ significantly from those discussed above for Ge(Li).

REFERENCES

- 2.1 C. M. Lederer, J. M. Hollander, I. Perlman, *Table of Isotopes*, 6th ed., (John Wiley and Sons, Inc., 1967). This is a tabulation of gamma rays from all radioactive isotopes. It includes nuclear energy level diagrams, x-ray information, and much more. It is a very useful reference for gamma-ray measurements.
- 2.2 J. E. Cline, "Gamma Rays Emitted by the Fissionable Nuclides and Associated Isotopes," Idaho Nuclear Corporation report IN-1448 (January, 1971), and supplement, "Gamma Rays Emitted by the Fissionable Nuclides and Associated Isotopes," Aerojet Nuclear Company report ANCR-1069 (July, 1972). This lists all gamma rays from the fissionable isotopes and related isotopes. It includes typical Ge(Li) spectra of the materials of interest. There are some significant discrepancies between this and Ref. 2.3 regarding line intensities.
- 2.3 R. Gunnink and R. J. Morrow, "Gamma-Ray Energies and Absolute Branching Intensities for ^{238}Pu , ^{239}Pu , ^{240}Pu , ^{241}Pu and ^{241}Am ," Lawrence Livermore Laboratory report UCRL-51087 (July, 1971). This lists gamma rays from the plutonium isotopes and shows typical Ge(Li) spectra. It probably contains the best available data on plutonium gamma-ray intensities.
- 2.4 R. Gunnink and J. F. Tinney, "Analysis of Fuel Rods by Gamma Ray Spectroscopy," Lawrence Livermore Laboratory report UCRL-51086 (August, 1971). Appendix C contains a listing of gamma rays from the fissionable isotopes (similar to Ref. 2.2).
- 2.5 USAEC Regulatory Guide 5.9, Specification of Ge(Li) Spectroscopy Systems for Material Protection Measurements--Part I: Data Acquisition.

3. PEAK STRIPPING AND BACKGROUND SUBTRACTION

3.1 Introduction

The information discussed in this section pertains to the basic procedures for extracting information from the measured gamma-ray spectrum. The basic data for the assay usually are the full energy peak areas of one or more gamma rays in the spectrum (e.g., from each isotope of interest, from an external transmission source used to measure sample attenuation, and from a reference source used to measure system livetime and pulse pileup). The Compton continuum which underlies these photopeaks must be subtracted to get the true source activity. In situations where this background is much less than the peak activity, only small errors are made by omitting the background subtraction, but in general this procedure is not recommended. For most nuclear material assay the peaks of interest are well resolved, and the background subtraction can be done by simple straightline subtraction procedures without the use of computer peak fitting techniques. This is certainly the case for assays based on the 186-keV and 414-keV peaks. The measurement of other plutonium isotopes, particularly ^{240}Pu , is often difficult even with the best peak fitting techniques, due to the severe interferences involved. Such techniques will not be discussed here.

3.2 Straightline Subtraction Techniques for Well Resolved Single Peaks

A simple, yet fairly general, method of determining photopeak areas is described below. The method is applicable to PHA data or to data obtained from scalers connected to single-channel analyzers. Figure 3.1 shows a portion of a pulse-height spectrum containing a single photopeak. The area under the peak, P , may be obtained by summing the contents of the channels as shown in the figure. The background under the peak can be approximated by a straight line, shown dashed in the figure. Groups of channels lying on each side of the peak may be averaged to estimate the background. If n_1 channels are used on the low side of the peak, n_2 channels are used on the high side, and n channels used in the peak (n should be equal to about 3 FWHM), then the background is given by

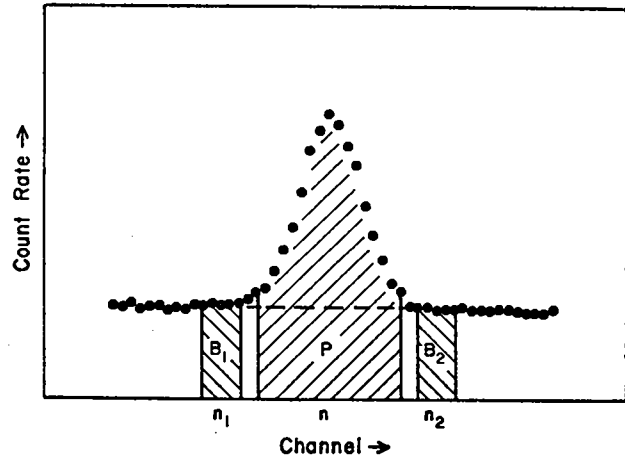

Fig. 3.1. Pulse-height spectrum of single photopeak illustrating general procedure for determining photopeak area. The area of interest is above the dashed line which is determined from B_1 and B_2 .

$$B = (n/2) \cdot (B_1/n_1 + B_2/n_2) \quad (3.1)$$

The peak area corrected for background is given by

$$A = P - (n/2) \cdot (B_1/n_1 + B_2/n_2), \quad (3.2a)$$

$$A = P - (n/2n_1) \cdot (B_1 + B_2), \text{ if } n_1 = n_2, \quad (3.2b)$$

$$A = P - (B_1 + B_2), \text{ if } n_1 = n_2 = n/2 \quad (3.2c)$$

If the slope of the straightline background is essentially constant for a particular set of measurements, then channels on one side of the peak only can be used for the background determination. The peak area would then be given by

$$A = P - (n/n_1) \cdot (k \cdot B) \quad (3.3)$$

where k is a factor that corrects for the background slope ($k = 1$ for a "level" background) determined from an appropriate calibration. This situation is illustrated in Fig. 3.2. This "two-window" procedure is commonly used with NaI-SCA instrumentation. For this, one SCA window is set over the peak and the other set slightly higher in energy. Scalers attached to the SCA's measure P and B , respectively (if only one SCA-scaler combination is available, two separate counts can be made at different threshold settings). The net peak area then becomes

$$A = P - (k \cdot B) \quad (3.3a)$$

where k is determined during the system calibration.

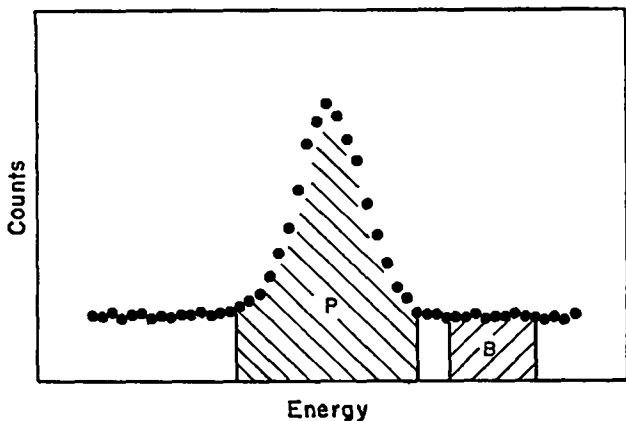

Fig. 3.2. Pulse-height spectrum of single photopeak illustrating two-window method for determining photopeak area. This is the most common procedure for NaI-SCA measurements.

It can be determined in several ways. The simplest is to choose k such that $A=0$ when no sample is in front of the detector. A better procedure is to use several standards of different uranium or plutonium masses and fit the measured responses to Eq. (3.3a). If the peak and background windows are of equal width, k should be about 1.3 for ^{235}U (186 keV) and 1.0 for ^{239}Pu (414 keV).

The statistical uncertainty of the measured areas should also be determined since this gives an estimate of the precision of the peak measurement. The expressions below give an estimate of the standard deviation in the area determined by Eqs. 3.2a-c.

$$\sigma(A) = \sqrt{P + (n/2)^2 \cdot [B_1/(n_1)^2 + B_2/(n_2)^2]}, \quad (3.4a)$$

$$\sigma(A) = \sqrt{P + (n/2n_1)^2(B_1 + B_2)}, \quad \text{if } n_1=n_2, \quad (3.4b)$$

$$\sigma(A) = \sqrt{P + B_1 + B_2}, \quad \text{if } n_1=n_2=n/2. \quad (3.4c)$$

These uncertainties should then be propagated through the full assay expression (including attenuation corrections, livetime and pileup corrections, etc.) to determine the total precision of the assay. An example of such a computation for a transmission-corrected scan is given in Ref. 3.1.

Two other background subtraction procedures deserve mention. The first is similar to the procedure described above but actually computes the equation of the background line and makes a channel-by-channel subtraction of the peak region. Refer

to Fig. 3.1; let (\bar{X}_1, \bar{X}_2) be the average channel number in the (lower, upper) background region. Let X_1 to X_n refer to the channel numbers in the peak region. The peak area is computed from the following expressions:

$$A = P - B, \quad (3.5)$$

where

$$B = \sum_{i=1}^n (mX_i + b),$$

$$m = \left(\frac{B_2}{n_2} - \frac{B_1}{n_1} \right) / (\bar{X}_2 - \bar{X}_1),$$

$$b = \frac{B_2}{n_2} - m\bar{X}_2.$$

For most single peaks this will give nearly the same area as is given by the first procedure. There are situations where several peaks are nearly resolved but there is not room to assign a background region next to the peak of interest. In such cases the background regions may be assigned on either side of the multiplet and the peak region assigned to the peak of interest. This latter procedure should be used to analyze such a situation (actually computer peak fitting techniques will usually be required to accurately analyze multiplets). An example of where this can be used is in the 160-keV region of the plutonium spectrum. With a good detector two peaks are nearly resolved, one at about 160.2 keV (from ^{241}Pu and ^{240}Pu) and one at 161.5 keV (from ^{239}Pu with a small americium contribution).

The other method, developed by Gunnink,^{3.2} uses a channel-by-channel background subtraction; however, the shape of the background is not linear. Consider the peak shown in Fig. 3.3. The background on the low energy side of a peak is usually higher than that on the high energy side (in most cases, the difference is not as large as illustrated here). This is due to small angle scatters in the sample and multiple Compton scatters in the detector. In the above procedures it is assumed that the variation between the two points is a straight line. The shape indicated in this figure is more physically accurate. The following procedure subtracts a background of this general shape. The same three regions are selected as in the other procedures. The total counts in these regions are P , B_1 and B_2 (as before), and the number of channels are n , n_1 , and n_2 .

The contents of the individual channels of the peak region are labeled P_1 through P_n . The area under the peak is given by the following expressions:

$$A = P - B \quad , \quad (3.6)$$

where

$$P = \sum_{j=1}^n P_j \quad ,$$

$$B = \sum_{i=1}^n \left(\frac{B_1}{n_1} - \Delta \frac{P_i}{P} \right) \quad ,$$

$$P_i = \sum_{j=1}^i P_j \quad ,$$

$$\Delta = \frac{B_1}{n_1} - \frac{B_2}{n_2} \quad .$$

This procedure will also work for nearly resolved multiplets as discussed above. For a single, well resolved peak this should not differ significantly from the area determined by the first procedure. In general, the first procedure will be adequate for well resolved single peaks. One of the other two methods should be used when trying to analyze peak multiplets without using peak fitting techniques.

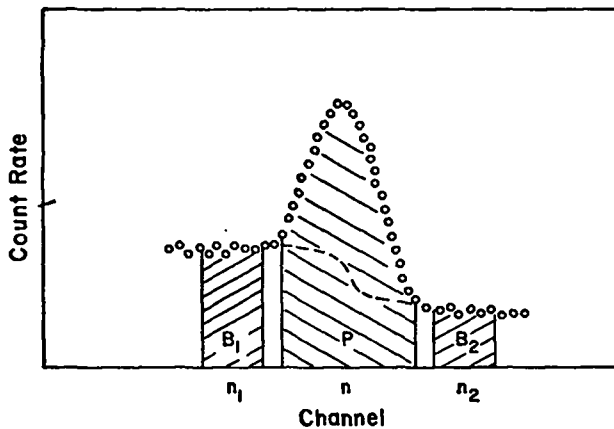

Fig. 3.3. Pulse-height spectrum of single photopeak illustrating Gunnink's procedure for determining photopeak area. The area of interest is above the dashed line. This is a more physical shape for the underlying Compton background than is used in Fig. 3.1.

3.3 Multiple Peaks

In some instances, as explained above, nearly resolved multiplets can be analyzed with simple channel summation algorithms. With adequate standards it is possible to get plutonium isotopic information from some peak multiplets using the procedures described in the previous section and nearby well resolved lines to evaluate the unresolved interferences (see Appendix A). For most situations, however, the accurate analysis of complicated peak multiplets requires the use of computer fitting techniques. References 3.3 - 3.5 give examples of such techniques. The peak shape algorithms used in GAMANAL have had the most success in extracting plutonium isotopic information from the complex plutonium spectrum.^{3.2} In closing, it should again be noted that these fitting procedures are not usually recommended or required for routine ^{235}U , ^{238}U , ^{239}Pu , or ^{241}Pu assay.

REFERENCES

- 3.1 E. R. Martin, D. F. Jones, "Computer-Oriented Gamma Scan System," Los Alamos Scientific Laboratory report LA-5379-MS (1973).
- 3.2 R. Gunnink, J. B. Niday, P. D. Siemens, "A System for Analysis by Gamma-Ray Spectrometry; Part I: Description of the Techniques for Analysis of Solutions," Lawrence Livermore Laboratory report UCRL-51577 Pt. 1 (1974).
- 3.3 R. Gunnink, J. B. Niday, "Computerized Quantitative Analysis by Gamma-Ray Spectrometry (The GAMANAL Program)," Lawrence Livermore Laboratory report UCRL-51061, Vol. I-III (1971).
- 3.4 R. G. Helmer, M. H. Putnam, "Gauss V, A Computer Program for the Analysis of Gamma-Ray Spectra from Ge(Li) Spectrometers," Aerojet Nuclear Company report ANCR-1043 (1972).
- 3.5 W. M. Sanders, D. M. Holm, "An Analytical Method for Unfolding Gamma-Ray Spectra, Los Alamos Scientific Laboratory report LA-4030 (1969).

4. DETECTOR EFFICIENCY AND THE INVERSE SQUARE LAW

The intrinsic photopeak efficiency of all detectors varies with energy. Typical examples of this variation are shown in Fig. 4.1 for NaI and Fig. 4.2 for Ge(Li). Knowledge of detector efficiency as a function of energy is required when attempting to make plutonium isotopic measurements by gamma spectrometry. Several lines at different energies are compared to extract isotopic ratios. As the figures illustrate, detection efficiency can change considerably over just several keV. It is often useful to have a plot of detector efficiency vs energy for all detectors in use (relative efficiency is usually adequate; the absolute counting efficiency is more difficult to measure accurately). This can be measured quite easily with the standard calibration sources available from NBS, IAEA, and others; or with the multi-isotopic point sources now available from NBS. It should be noted that absolute counting efficiency need not be known since all gamma assay should be based on

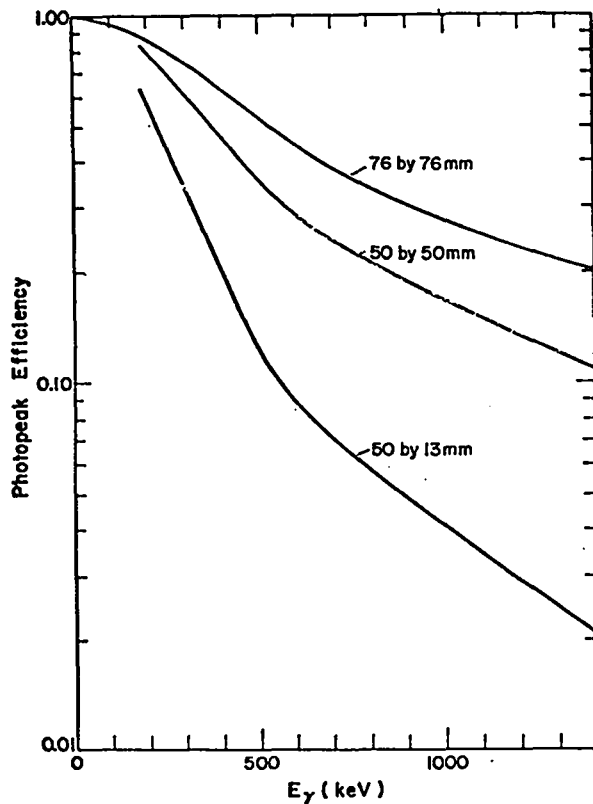

Fig. 4.1. Photopeak efficiency vs energy for three different size NaI detectors.

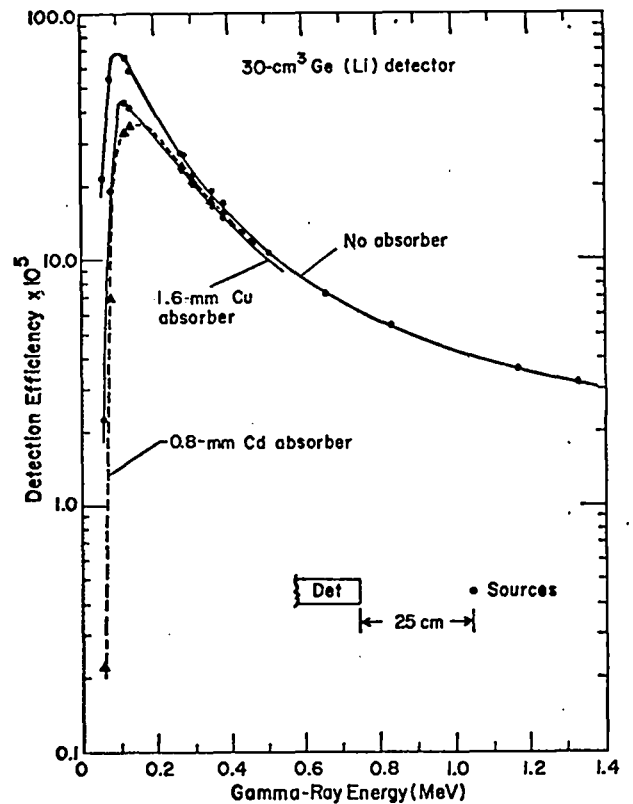

Fig. 4.2. Absolute efficiency vs energy for 30-cm³ Ge(Li) detector.

measurements made relative to a known calibration standard. A measurement of absolute efficiency is implicit in the standard calibration.

The variation in efficiency with source-to-detector distance affects gamma-ray assay in an obvious and important way. The basic formula for the absolute efficiency to detect gamma rays from a point source is given as

$$\epsilon_T = \frac{A \cdot \epsilon_p}{4 \pi r^2} \quad (4.1)$$

where

- A = visible detector area,
- ϵ_p = detector photopeak efficiency,
- r = source-to-detector distance.

Most samples for fissionable material assay are extended sources, so r and ϵ_T vary from one point to another on the sample. This means a gram of uranium may yield different count rates depending on its location within the sample. Consider the cross section

of a 55-gal drum (diam = 60 cm) illustrated in Fig. 4.3. One gram of material in position 2 counts four times as much as in position 4. If all samples were uniform, this variation of response (count rate) with position would be unimportant.

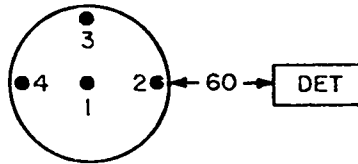

$$\begin{aligned}
 r_1 &= 90 \text{ cm} & CR_1/CR_1 &= (90/90)^2 = 1 \\
 r_2 &= 60 & CR_2/CR_1 &= (90/60)^2 = 2.25 \\
 r_3 &= 95 & CR_3/CR_1 &= (90/95)^2 = 0.90 \\
 r_4 &= 120 & CR_4/CR_1 &= (90/120)^2 = 0.56
 \end{aligned}$$

Fig. 4.3. Illustration of count rate variation with position in 55-gal drum.

Since many samples are not uniform (particularly the waste stored in 55-gal drums), this represents a potential source of error and should be minimized. This can be accomplished by increasing the sample-to-detector distance, but only at the expense of count rate. If the detector in Fig. 4.3 were 120 cm from the drum edge, the ratio of count rates between position 2 and position 1 would be $(150/120)^2 = 1.56$, but the overall count rate would have dropped to nearly one-third that at 60 cm. A better procedure is to rotate the sample. Consider the following diagram.

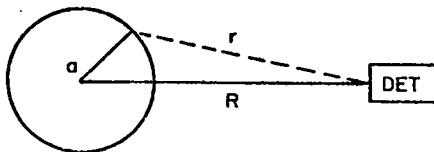

The ratio of the average response of a source rotating on the radius (a) to the response at the center is

$$\frac{CR(a)}{CR(0)} = \frac{1}{1 - (a/R)^2} \quad (4.4)$$

Table 4.1 lists this function for several values of a/R. By rotating the sample the maximum count rate variation in Fig. 4.3 due to position is reduced from 2.25 to 1.125 with no loss in overall count rate. Thus, whenever possible the sample should be

TABLE 4.1
THE EFFECT OF SAMPLE ROTATION ON
COUNT RATE VARIATION

a/R	CR(a)/CR(0) Rotating	CR(R-a)/CR(R) Not Rotating
1/2	1.33	4
1/3 ^a	1.125	2.25
1/4	1.067	1.78
1/5	1.042	1.56
1/6	1.029	1.44
1/7	1.021	1.36

^a This is the case illustrated in Fig. 4.3.

rotated to minimize the potential error due to non-uniform distributions of material within the sample. Rotation minimizes the effect of radial variations. If the sample is taller than it is wide, the vertical variation must be considered also. This is illustrated in Fig. 4.4, where $L = \frac{1}{2}$ height of container and $n \cdot L =$ distance from detector to center of container. The maximum variation is reduced to 10% with a sample-to-detector of 3L.

In general, the choice of sample-to-detector distance is a compromise between minimizing the response variation and maintaining an adequate count rate. A general guideline can be given as follows: The maximum count rate variation with position is less than $\pm 10\%$, if the distance between the center of the sample and the detector is equal to or greater than three times the larger of the dimensions a or L (radius or $\frac{1}{2}$ height) and the sample is rotated. If the sample cannot be rotated, it should

$$\frac{\Delta CR}{CR} \leq 10\%, \text{ if } R \geq 3a \text{ or } 3L, \text{ whichever} \quad (4.5)$$

is larger, where a = radius of sample and $L = \frac{1}{2}$ height and the sample is rotated. This applies to $1/r^2$ variations only.

at least be counted in two orientations 180° apart. Usually there will be little need to increase the sample-to-detector distance beyond this because of considerations of sample attenuation which will usually be the largest source of count rate variation.

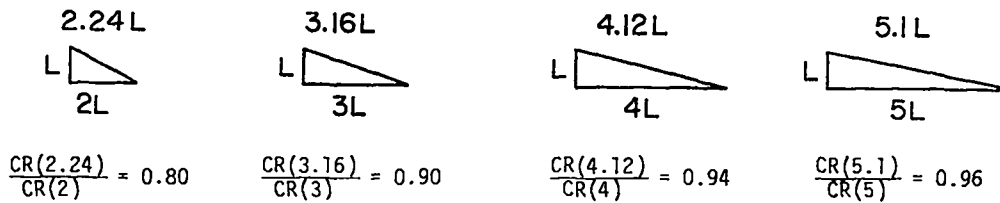

Fig. 4.4. Maximum vertical count rate variation as a function of sample-to-detector distance.

A source at the center of the sample will experience a larger attenuation than will a similar source near the edge. This effect cannot be minimized by increasing the sample-to-detector distance. In most samples it will be the dominant effect, so sample-to-detector distances larger than indicated by the above discussion and Eq. (4.5) are usually of little value. Consider a 55-gal drum of com-

bustible waste ($a = 30$ cm, density ≈ 0.1 g/cm³ or about 45 lb net weight, $\mu_m(414) \approx 0.1$ cm²/g). Only 74% of the gamma rays emitted at the center would reach the surface of the drum ($e^{-(0.1)(0.1)(30)} = 0.74$). This is a maximum count rate variation of 26%, so a sample-to-detector distance larger than specified by Eq. (4.5) would not be justified.

5. ATTENUATION CORRECTION FACTORS

5.1 General Attenuation Considerations

Figure 5.1 is a graph of mass attenuation coefficients vs energy for a selected range of elements. It also indicates the energies of the more useful gamma rays for the assay of several important isotopes. In a qualitative way, the figure indicates many of the possibilities and constraints in performing gamma-ray assays. Several important features should be emphasized. Between 1 and 3 MeV, the mass attenuation coefficients of all elements (except hydrogen) are equal at a given energy within $\sim \pm 20\%$. The maximum and minimum values within this range are $\sim 0.08 \text{ cm}^2/\text{g}$ and $\sim 0.035 \text{ cm}^2/\text{g}$ and the overall average value in the range is $\sim 0.05 \text{ cm}^2/\text{g}$. If nature had equipped all the isotopes of interest with an intense gamma ray in this range, gamma-ray assay would be much easier, but unfortunately only ^{238}U is so equipped. At lower energies, the coefficients

of the high-Z elements of interest become much larger than those of the lower-Z materials, reaching values ~ 20 times higher near the K-absorption edge of plutonium. These large differences make quantitative assay by low energy gamma rays difficult, or even impossible in many cases. The mass absorption coefficients of uranium and plutonium are nearly six times larger at 186 keV than at 414 keV. This means the assay of ^{235}U (using its 186-keV gamma ray) is subject to a greater potential error than the assay of ^{239}Pu (using its 414-keV gamma ray). The region between 80 and 120 keV is usually not useful for assay measurements due to the K x rays of uranium and plutonium. Below 80 keV most attenuation coefficients increase rapidly, making attenuation unmanageably severe for most cases. An exception to this is the measurement of very low level ($\sim 10 \text{ nCi/g}$) waste materials where L x rays ($\sim 20 \text{ keV}$) must be measured to achieve the desired sensitivity. Nearly all uranium and plutonium assay is done with gamma rays of energies between 100 and 1000 keV.

Figure 5.1 and the discussion above indicate the existence of limitations and constraints due to sample self-attenuation. The correction for sample attenuation will be discussed in some detail since it is the most important factor in gamma-ray assay. The attenuation correction factor is defined here by the following expression:

$$CF = \frac{CR(\mu=0, \text{ no attenuation})}{CR(\text{actual observed rate})} \quad (5.1)$$

where

CR = count rate,

CF = attenuation correction factor.

This expression is symbolic. CF cannot be computed from Eq. (5.1) because $CR(\mu=0)$ cannot be measured directly. The product $CR \cdot CF$ is sometimes called the "corrected count," i.e., the count which would be measured in the absence of attenuation. As defined, the correction factor has a minimum value of one. Experience has shown that the maximum value that can be determined with reasonable accuracy ($\pm 5\%$) is about five. It should be emphasized that $CF=5$ is a large correction implying that only 20% of the gamma rays of interest escape from the sample.

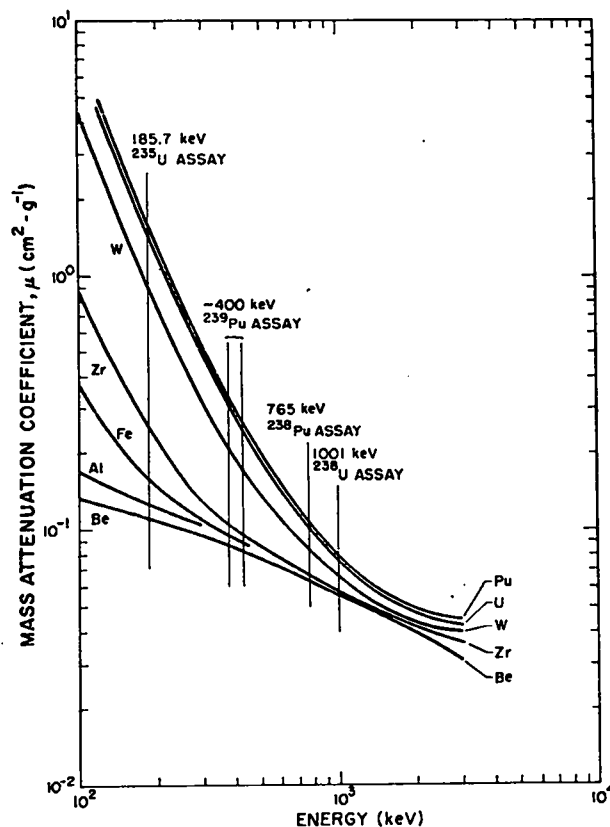

Fig. 5.1. Mass attenuation coefficient vs energy for selected elements. The energies of several important assay lines are indicated on the graph.

Large values of CF imply high potential for error. Sample nonuniformities become more troublesome as CF increases.

The basic necessary assumption for all quantitative gamma assay is that the mixture of uranium or plutonium and matrix material (everything other than uranium or plutonium in the sample) is reasonably uniform, and the uranium or plutonium particles are small enough to ignore self-attenuation within the emitting particles. It is difficult to define "reasonably uniform," but some rough guidelines can be discussed. If the individual particles of uranium or plutonium have significant self-attenuation, the assay results will be low. For some cases special procedures may be used to correct for the error caused by individual particle attenuation. The self-attenuation of the individual particles can be estimated from the following formula.

$$CF = \frac{\mu x}{1 - e^{-\mu x}} \quad (5.2a)$$

$$CF \approx 1 + \mu x/2, \text{ if } \mu x \leq 1 \quad (5.2b)$$

$$CF \approx \mu x, \text{ if } \mu x \geq 3 \quad (5.2c)$$

where

μ = linear attenuation coefficient of emitting material,

x = mean linear dimension of particle.

(The approximations are good to 5%.) The actual particles are irregular shapes and their size is not usually well known, so it is difficult to compute the self-attenuation exactly. This formula should only be used to estimate the order of magnitude of the particle self-attenuation. Figure 5.2 illustrates the variation of self-attenuation with size for uranium and plutonium oxide particles. As indicated in the figure, small particles can have significant self-attenuation, particularly uranium. A 130- μ particle of uranium oxide will absorb 10% of the 186-keV gamma rays emitted within the particle. Larger particles, such as fuel pellets, are even worse. A 1-cm pellet of UO_2 requires a correction factor of about 15 [$\mu x \approx (1.5 \text{ cm}^2/\text{g}) \times (10 \text{ g/cm}^3)(1 \text{ cm}) = 15$] for the 186-keV gamma ray. A similar plutonium recycle pellet would require a correction factor of about 2.5 for the 414-keV gamma ray. If such pellets were in a container of low density combustible waste (rags, gloves, Kim-

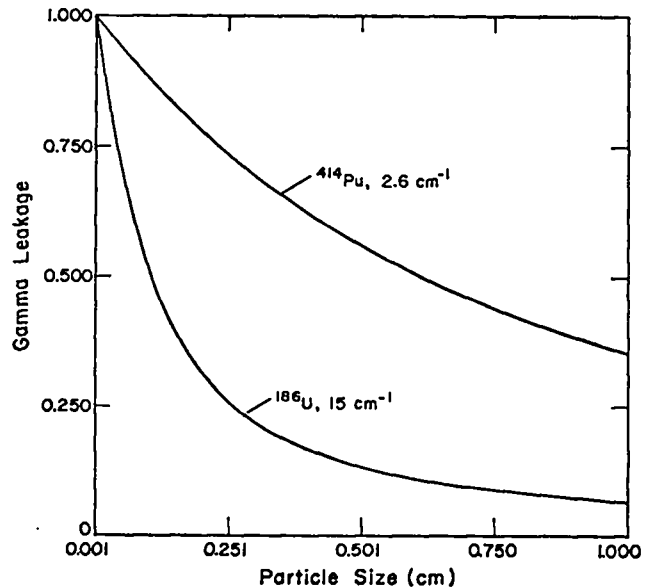

Fig. 5.2. Self-attenuation vs particle size.

wipes, etc.), the package would clearly not meet the requirement of reasonable uniformity. HTGR-coated particles come close to meeting the requirement, but assay results will still be 5-10% low if corrections are not made for particle size. Pure powders (PuO_2 , UO_2 , U_3O_8 , etc.) clearly meet the requirement as do certain well mixed powder scrap materials, such as most incinerator ash. Small quantities of powder mixed with combustibles may meet the requirement if the powder is distributed uniformly in the matrix and not in lumps.

The above discussion illustrates some of the basic problems of gamma-ray assay. There are some techniques which allow less stringent uniformity conditions, which will be mentioned below. Nevertheless, it is generally true that in order to perform gamma-ray assay with any assurance of accuracy, the assayist must know that the samples meet the basic assumption of uniformity. In favorable cases, accuracies of $\pm 5\%$ (1 σ) are readily obtainable; however, for samples which grossly depart from uniformity, measurements can be low by a factor of two or more. Several common ways of computing the attenuation correction factor will now be discussed.

5.2 Attenuation Correction Factor Expressions

Equations (5.3) list several common and useful expressions for the correction factor.

$$CF = \frac{\mu D}{1 - e^{-\mu D}} \quad \text{slab,} \quad (5.3a)$$

$$CF = \frac{\pi/4 \mu D}{1 - e^{-\pi/4 \mu D}} \quad \text{cylinder,} \quad (5.3b)$$

$$CF = e^{+\mu L} \quad \text{absorber.} \quad (5.3c)$$

In these expressions D is the cylinder diameter or or slab thickness, and L is the thickness of any pure absorbers between the sample and the detector. The slab formula, Eq. (5.3a), is an exact expression for the case where the sample-to-detector distance is very large compared with the dimensions of the source and the detector (this is sometimes called the far-field approximation). It is used for rectangular samples (plates, boxes, air filters, etc.) viewed parallel to a side (usually through the thin dimension). The expression works well even for fairly small sample-to-detector distances (one or two times the sample thickness). Equation (5.3b) is an approximate expression for cylindrical samples. It has the same form as Eq. (5.3a), with μD replaced by $(\pi/4)\mu D$ ($\pi/4=0.785$). This expression works quite well even when the detector is only one diameter from the edge of the sample. Both Eqs. (5.3a) and (5.3b) are plotted in Fig. 5.3. Equation (5.3c) is merely the fundamental law of gamma attenuation and is used for absorbers placed between the sample and the detector. This expression would be applied to the walls of the sample container. For this case, the total correction factor would be the product of Eq. (5.3a) or (5.3b) times Eq. (5.3c).

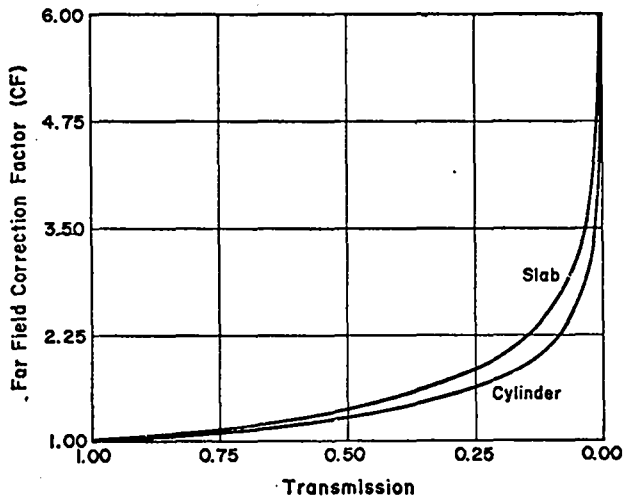

In general, these expressions are approximate but quite accurate, particularly for use with high resolution detectors. For NaI they usually over-estimate CF due to the effects of small angle scatterers in the sample. In many cases, μD can be determined by an external source transmission measurement as described below. Other times (e.g., equipment holdup and large waste containers) μD is estimated from knowledge of the sample and CF computed directly from the appropriate expression above.

5.3 Transmission-Corrected Gamma-Ray Assay

Consider the situation pictured in Fig. 5.4. The sample is placed between the detector and an external gamma-ray source. I_0 is the measured intensity of the source with no sample, and I is the intensity with the sample in place. The transmission, T , is defined as

$$T = I/I_0, \quad (5.4a)$$

i.e., the fraction of gamma rays from the source which pass through the sample with no change in

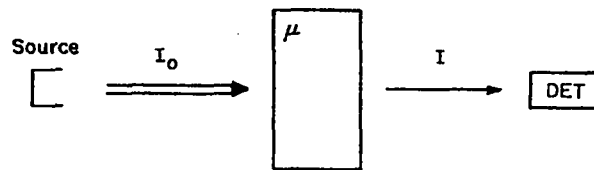

Fig. 5.4. Diagram of a transmission measurement.

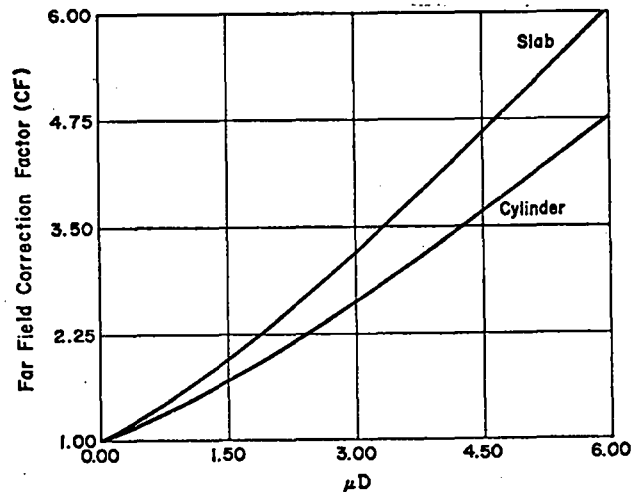

Fig. 5.3. Attenuation correction factor vs μD (right) and transmission (left).

energy or direction. From the fundamental attenuation relationship,

$$T = e^{-\mu D} \quad (5.4b)$$

The correction factor Eqs. (5.3) can be rewritten in terms of T.

$$CF = \frac{-\ln T}{1 - T} \quad \text{slab,} \quad (5.5a)$$

$$CF = \frac{-\pi/4 \ln T}{1 - T^{\pi/4}} \quad \text{cylinder.} \quad (5.5b)$$

Figure 5.3 also shows a plot of CF vs T. For T greater than 0.2, CF is less than 2.0 and does not change rapidly. This is a favorable range for assay work. For T less than 0.2, CF rises rapidly and the possibility of error increases. Measured transmissions become less accurate when T is less than 10%. For careful work with high resolution detectors, transmissions as low as ~ 0.5% (CF ~ 5.3) can be measured with confidence. Caution is advised when measuring transmissions below 10% with NaI. The effects of small angle (small energy change) Compton scattering or "buildup" are more troublesome for NaI measurements.

Table 5.1 lists some of the common transmission sources. Equations (5.5a) and (5.5b) assume the transmission is measured at the same energy as the assay gamma ray. As indicated in Table 5.1, transmission and assay energies may be quite different. In this case a correction must be applied for the difference in attenuation between the two

energies. This correction usually involves some knowledge of the composition of the sample. The relation between the transmissions at the two energies is given by

$$T_a = T_t^\alpha \quad (5.6)$$

where

a refers to the assay energy,

t refers to the transmission energy,

$$\alpha = \mu_a / \mu_t.$$

The measured transmission is raised to the μ_a / μ_t power before substitution into Eqs. (5.5). As an example of how reasonable values of α may be obtained, consider the assay of ^{239}Pu (414 keV) contaminated incinerator ash using ^{137}Cs (662 keV) as a transmission source. This mixture can be treated as two components, one having the attenuation properties of oxygen and the other those of plutonium, in calculating the composite attenuation. Table 5.2 illustrates the change in $\alpha(\mu_a / \mu_t)$ with the plutonium weight fraction. Most incinerator ash will be less than 10% plutonium by weight, so $\alpha=1.27$ might be picked as an average value for the measurements. If a wider range of weight fractions is encountered, it may be necessary to perform an iteration (i.e., pick a trial F_{pu} , calculate the mass of plutonium, calculate F_{pu} from this value and the sample net weight, recompute the mass of plutonium, etc.).

The choice of a transmission source is frequently limited by the equipment and sources

TABLE 5.1
COMMON TRANSMISSION SOURCES

Assay Isotope	Assay Energy (keV)	Transmission Source	Transmission Energy (keV)
^{235}U	186	^{169}Yb	177, 198
		^{235}U	186
^{238}U	1001	^{137}Cs	662
		^{54}Mn	834
		^{22}Na	1275
^{239}Pu	414	^{75}Se	401
		^{22}Na	511
		^{137}Cs	662
		^{239}Pu	414

TABLE 5.2
THE VARIATION IN $\mu(414)/\mu(662)$ WITH
PLUTONIUM WEIGHT FRACTION

F_{pu}	$\alpha = \mu(414)/\mu(662)$	
0	1.21	
0.1	1.33	
0.3	1.54	
0.5	1.71	
0.7	1.84	
0.9	1.95	
Mass Attenuation Coefficients		
	414	662
μ_{pu}	0.26 cm ² /g	0.13 cm ² /g
μ_{o}	0.093	0.077

available. Uranium or plutonium is usually available, and neither of them requires any energy correction as above. There are, however, three bad aspects of their use: they require a double measurement (with and without the source) to compensate for the uranium or plutonium activity in the sample; at low transmissions this requires the subtraction of two large and nearly equal numbers, the result of which usually has a low statistical precision; and, finally, the high self-attenuations of uranium and plutonium make it difficult to get high intensity sources. Sources such as ^{169}Yb and ^{75}Se are usually chosen for use with high resolution detectors. With ^{169}Yb the transmission is measured at both 177 and 198 keV. The 186-keV transmission is determined by interpolation. With ^{75}Se the transmission energy (401 keV) is close enough to the assay energy (414 keV) to consider $\alpha=1$. NaI requires the use of uranium or plutonium or sources such as ^{22}Na and ^{137}Cs which are of sufficiently different energy as to reduce the interference with the plutonium gamma rays.

If the sample is uniform, one transmission measurement will adequately define μD . In more advanced procedures the sample is scanned to measure T as a function of position.

5.4 Differential Absorption Correction

This is another measured attenuation correction of use for some types of nuclear material assay. It is based on two facts. First, some isotopes emit several gamma rays with significantly different energy. Thus, the ratio of the intensities of two different energy gamma rays from the same isotope will vary with the sample attenuation. In certain circumstances this ratio can define the sample attenuation correction factor.

To apply this method the same assumptions are required as discussed above for transmission corrected assay. Several additional requirements must be met:

- (a) The average or effective atomic number (Z) must be known; i.e., some knowledge of sample composition is required.
- (b) The uranium or plutonium must be a small part of the total sample attenuation.

(c) The required homogeneity and lack of self-absorbing uranium or plutonium concentrations is more severe than for transmission corrected assays.

(d) The isotope must have appropriate gamma rays. (It should be noted that the correction lines need not come from the isotope under assay; e.g., intense lines from ^{241}Pu can be used for ^{239}Pu assay.)

A major advantage of this technique is its simplicity. It requires only a detector and a sample. It is most applicable to plutonium assay; and, since individual plutonium gamma rays must be measured, a Ge(Li) detector is required. A multichannel analyzer and computer will usually be required for data acquisition and analysis.

Cline describes a procedure for the measurement of plutonium contaminated waste based on the differential absorption method.^{5.1,5.2} The absorption correction is based on the ratio of the intensities of the 129- and 414-keV gamma rays of ^{239}Pu . The expression derived for the attenuation correction factor is

$$\text{CCF} = \left[\frac{(I_{129}/I_{414})_{\text{em}}}{(I_{129}/I_{414})} \right]^{\mu_{129} - \mu_{414}}, \quad (5.7)$$

where

- CCF = differential absorption attenuation correction factor,
- μ_{414}, μ_{129} = mass attenuation coefficients for the appropriate atomic number,
- (I_{129}/I_{414}) = ratio of gamma ray intensities for the measured sample,
- $(I_{129}/I_{414})_{\text{em}}$ = ratio of gamma ray intensities for a sample with negligible attenuation. A thin foil is recommended to measure this.

The average atomic number of the waste matrix must be known to apply this procedure. For much combustible waste this is approximately $Z=8$, and the exponent in Eq. (5.7) has a value of ~ 1.92 . Figure 5.5 shows a graph of this exponent with respect to atomic number. Several assumptions are made in the derivation of this expression, so it only holds over a limited attenuation range. The combustible waste situation is illustrated in Table 5.3. The table compares Eq. (5.7) (CCF) with

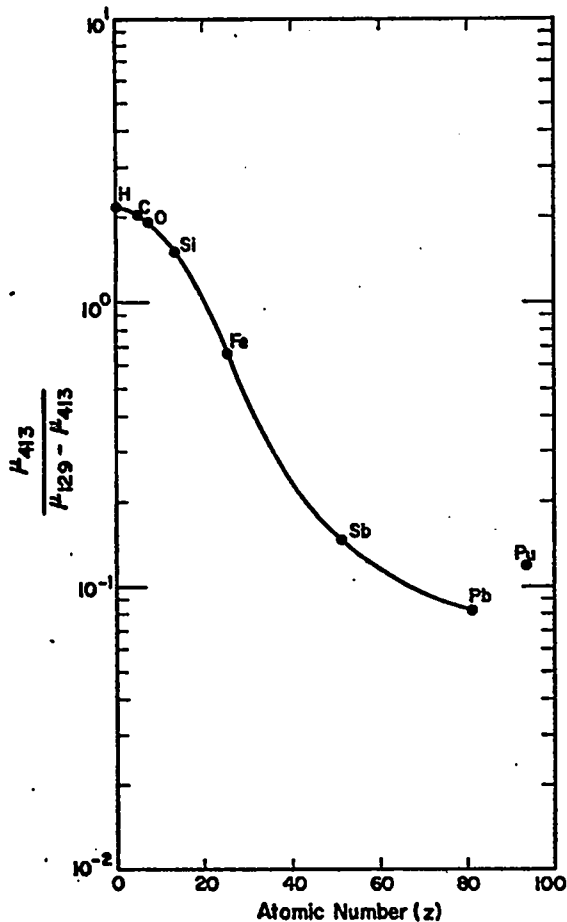

Fig. 5.5. Exponent in Equation (5.7), $\frac{\mu_{414}}{\mu_{129} - \mu_{414}}$, as a function of atomic number. Taken from Ref. 5.1.

Eq. (5.3b) (CF_{414}) as a function of waste density. This shows that Eq. (5.7) should not be used if the 129/414 ratio drops below 75-80% of the unattenuated value. It should be noted that most combustible waste will have a density of $\leq 0.3 \text{ g/cm}^3$; therefore, the expression should be adequate if the 75-80% limit is observed.

A more correct procedure can be given to compute the differential absorption correction factor. Consider two gamma rays labeled 1 and 2 (2 is the higher energy and is the line used for assay; e.g., 1-129 keV, 2-414 keV). The average atomic number (or some assumption of matrix composition) gives the two mass attenuation coefficients, μ_1 and μ_2 . The measured intensity ratio I_1/I_2 is given by

$$\frac{I_1}{I_2} = \left(\frac{I_1}{I_2} \right)_{em} \frac{CF_2}{CF_1}, \quad (5.8)$$

where

$$\frac{CF_2}{CF_1} = \frac{\mu_2}{\mu_1} \frac{1 - e^{-\mu_1 X}}{1 - e^{-\mu_2 X}} \quad \text{slab},$$

$$\frac{CF_2}{CF_1} = \frac{\mu_2}{\mu_1} \frac{1 - e^{-(\pi/4)\mu_1 X}}{1 - e^{-(\pi/4)\mu_2 X}} \quad \text{cylinder},$$

X = density \cdot thickness (diameter).

The correction factor is determined as follows:

- (1) Values for μ_1 and μ_2 are determined for the assumed matrix composition.

TABLE 5.3
COMPARISON OF DIFFERENTIAL ABSORPTION AND
TRANSMISSION-BASED ABSORPTION CORRECTIONS
FOR COMBUSTIBLE WASTE

Density (g/cm^3)	$\frac{I_{129}/I_{414}}{(I_{129}/I_{414})_{em}}$	T_{414}	CCF	CF_{414}	Diff. (%)
0.1	0.89	0.54	1.24	1.26	-1
0.2	0.82	0.29	1.47	1.56	-6
0.3	0.76	0.16	1.56	1.89	-12
0.4	0.73	0.09	1.84	2.25	-19
0.6	0.69	0.03	2.05	3.06	-33
0.8	0.67	0.01	2.16	3.94	-45
1.0	0.66	0.002	2.20	4.85	-55

(2) Iterate Eq. (5.8) to find the value X which produces the measured line ratio I_1/I_2 .

(3) Compute CF_2 (the desired attenuation correction) from:

$$CF_2 = \frac{\mu_2 X}{1 - e^{-\mu_2 X}} \quad \text{slab} \quad , \quad (5.9)$$

$$CF_2 = \frac{(\pi/4)\mu_2 X}{1 - e^{-(\pi/4)\mu_2 X}} \quad \text{cylinder} \quad .$$

The maximum possible change in the ratios is given by:

$$\left. \frac{I_1/I_2}{(I_1/I_2)_{em}} \right)_{\text{minimum}} \approx \frac{\mu_2}{\mu_1} \quad . \quad (5.10)$$

As the attenuation of the low energy line reaches saturation, the method loses sensitivity to changing attenuation. This correction procedure should not be applied when the ratio gets below

$$\left. \frac{I_1/I_2}{(I_1/I_2)_{em}} \right) \approx 1/3 + 2/3 \frac{\mu_2}{\mu_1} \quad . \quad (5.11)$$

By itself the differential absorption method is best suited to low level plutonium contaminated combustible waste. It may also be applicable to some small containers of solid residue such as incinerator ash. There is relatively little experience with this latter category. If the matrix is too dense (1.0 g/cm³ should still be measurable in a 12-cm or less diameter can) the 129-keV gamma ray is saturated and the attenuation correction cannot be evaluated. When the sample does meet the necessary requirements, this method can be recommended due to the ease of operation. It also has the

necessary feature that it includes an indication of when the sample is not measurable by differential absorption, namely, when the intensity ratio drops below the value given by Eq. (5.11).

There are several potential gamma-ray pairs which may be used in plutonium assay. There is really only one that might be used for uranium, and this only for certain special situations. Information is given on several line pairs in Table 5.4. The 143, 186 or 345, 414 combinations will generally not be useful for combustible waste assay since there is not enough difference between μ_1 and μ_2 . These lines may provide information on uranium or plutonium lumps as indicated below. The value, $(I_1/I_2)_{em}$, is just the ratio of the relative intensities of the two gammas. The actual measured ratio will be affected by the different detection efficiencies at the two energies.

Another important use of the differential absorption method is to indicate the presence of source self-absorption (uranium or plutonium lumps) in samples undergoing transmission-corrected gamma assay. If the observed ratio (e.g., 129/414) is significantly lower than is indicated by the standards, the presence of lumps should be suspected. For this purpose the 143/186 ratio can provide some limited information for uranium assay. The 345/414 ratio may be better for plutonium since the 129-keV line is too highly absorbed by plutonium (it will saturate and indicate trouble when the 414-keV transmission-corrected assay is still okay). For plutonium assay it is recommended that either or both of the above ratios be monitored to check for anomalous source absorption. In principle it may even be possible to make some compensation for the

TABLE 5.4
GAMMA-RAY PAIRS FOR DIFFERENTIAL ABSORPTION METHOD

Isotope	Energy (keV)	$I_1/I_2)_{em}$	Mass Absorption Coefficient		$\left. \frac{I_1/I_2}{(I_1/I_2)_{em}} \right)_{\text{min}}$	
			Combustible Waste (cm ² /g)	U or Pu (cm ² /g)	Comb.	U or Pu
²³⁵ U	143, 186	0.10	.154, .141	2.9, 1.5	0.42	0.52
²³⁹ Pu	129, 414	3.7	.156, .104	3.8, 0.28	0.67	0.074
²³⁹ Pu	345, 414	0.33	.111, .104	0.4, 0.28	0.94	0.70

self-absorbing lumps. For example, multienergy transmission measurements [e.g., for 143/186: 131-, 177-, 198-keV lines from ^{109}Yb ; for 129/414, 122-keV (^{57}Co) and 401-keV (^{75}Se)] can be used to predict the intensity ratio which should be measured if there are no lumps and the transmission source is accurately measuring the total absorption. If the measured ratio is significantly below this, the difference can be ascribed to uranium or plutonium lumps and an appropriate correction made. This would never be a routine procedure, but it might be of use in certain assay situations.

To summarize, the differential absorption technique is more restricted than transmission-corrected assay but, where applicable, is easier to use. It does provide a warning when it cannot be used. It complements transmission-correction techniques and can provide additional information in some assay situations. Appendix B contains a description of some recent work on the differential absorption technique and should be read carefully by anyone contemplating the use of this procedure.

5.5 Other Attenuation Corrections

Equations (5.12) give an approximate expression for a transmission-based correction factor which may be used for transmissions over ~ 0.2 .

$$CF \approx 1/\sqrt{T} \quad \text{slab} \quad (5.12a)$$

$$CF \approx 1/\sqrt{T\pi/4} \quad \text{cylinder} \quad (5.12b)$$

This assumes that the average path length within the sample is one-half the slab thickness or one $\pi/8$ th of the cylinder diameter. Table 5.5 gives a comparison of Eqs. (5.12) with the exact expressions, Eqs. (5.5). For T greater than 0.2 the approximate slab expression is less than 12% and the cylinder expression is less than 7% high.

In some cases, useful estimates of CF can be made from knowledge of the sample weight and composition. If the sample is full and its weight and composition known, the attenuation may often be calculated with sufficient accuracy that no experimental measurement is required. Consider the example of a 55-gal drum of plutonium-contaminated combustible waste. The waste material must be well segregated (i.e., no lathe beds, balls mills, etc., mixed with the combustibles) and the plutonium con-

TABLE 5.5
COMPARISON OF APPROXIMATE AND EXACT
EXPRESSIONS FOR CF

T	$1/\sqrt{T}$	$\frac{-\ln T}{1-T}$	$1/\sqrt{T\pi/4}$	$\frac{-\pi/4 \ln T}{1-T\pi/4}$
1.0	1.0	1.0	1.0	1.0
0.8	1.118	1.116	1.092	1.090
0.6	1.291	1.277	1.222	1.214
0.4	1.581	1.527	1.433	1.402
0.2	2.236	2.012	1.881	1.761
0.1	3.162	2.558	2.469	2.162

centration low so that it is a minor part of the total attenuation. Combustible waste will have attenuation properties similar to water.

Assume net weight = 32 kg; size = 56 cm diam by 89 cm high; walls = 0.1 cm; volume = 0.22 m^3 . Straightforward computation using Eq. (5.3b) gives for the matrix CF = 1.37, and using Eq. (5.3c) for the wall attenuation one gets CF = 1.07; this gives a combined correction factor for matrix and container of $1.37 \times 1.07 = 1.47$. Again using Eq. (5.3b) and assuming 100 g of plutonium distributed uniformly throughout the drum, one gets CF = 1.003. This says that 100 g of plutonium will have a negligible effect on the total gamma-ray attenuation in the drum if it is distributed so that there are no self-attenuating lumps.

The important factor in applying this attenuation correction is that the containers must be filled or the fill volume known. The attenuation correction is based on the density of the sample. Consider a group of samples filled to different heights with material of approximately constant density. Since the density is constant, the correction factor should be constant. However, if only the weight is known and the samples are assumed to be full, different correction factors will be applied to each sample.

The final procedure to be discussed involves the use of standards to cover the range of material to be measured. In this case no explicit computation or measurement is made to correct for attenuation; the unknowns are assumed to have the same attenuation properties as the standards. This procedure is acceptable where there is a class of

samples which are very nearly identical in size, shape, and composition, varying only in concentration of uranium or plutonium. In such cases, the attenuation of the matrix will be nearly constant from one sample to another and the observed count rate will be uniquely related to the fissionable material concentration. This relationship can be determined by preparing a series of standards covering the expected concentration range and counting them in the same geometry as the unknowns. The resulting calibration curve may be somewhat nonlinear if the uranium or plutonium concentration is high enough that it begins to contribute to the attenuation in the standard. This procedure is the simplest to use, and where applicable, can yield acceptable results (at present, it is probably the most widely used gamma assay procedure). For example, this would be used for product control or quality assurance where deviations from a mean (the standard) are to be measured. However, it is the most susceptible to error and must be applied with caution. It should only be used on very well controlled material since there is no check that the unknowns actually do resemble the standards. The standards must have the same matrix attenuation as the unknowns, or else there

will be a constant bias on all measurements. This procedure is generally not recommended. Its undesirable features are discussed in detail in Section 9 (Standards).

REFERENCES

- 5.1 J. E. Cline, "A Relatively Simple and Precise Technique for the Assay of Plutonium Waste," Aerojet Nuclear Company report ANCR-1055 (February, 1972). This report describes the use of differential attenuation of different energy plutonium gamma rays to correct for sample attenuation. It also includes a good discussion of the operation of Ge(Li) detectors and their associated electronics. This should be read in conjunction with the next reference, which describes some of the assumptions and limitations of the "contrast method" and reports some experimental results on plutonium waste standards.
- 5.2 T. D. Reilly and J. L. Parker, Los Alamos Scientific Laboratory report LA-5197-PR (1972), pp. 15-18. This report contains some discussion of Ref. 5.1 and some measurement results on mixed oxide (uranium-plutonium) waste standards.

6. RATE-RELATED COUNTING LOSSES

6.1 Nature of the Problems: Methods of Minimization

Failure to record (or to correctly record) gamma-ray interactions in the detector because of the rate-dependent effects of instrumental deadtime and/or pulse pileup is a significant potential source of error in gamma-ray assays. Such counting losses have been dealt with in various books and papers.^{6.1 - 6.4} However, for the sake of completeness, a brief discussion will be given here along with suggestions for a few specific procedures for correcting such losses.

The term "deadtime," of course, generally refers to the fact that some components of common data acquisition systems (usually single or multichannel analyzers) have a finite "deadtime" or analysis time during which they cannot accept another event. This deadtime per event ranges from a few microseconds for single-channel analyzers to several tens of microseconds for most multichannel analyzers. In the latter case the total fraction of deadtime may often be several tens of percent. Most multichannel analyzers have a good internal correction for their own deadtime if the spectral shape remains constant during the count interval. It should be noted that if the spectral shape is not constant, the deadtime correction for different spectral components will differ. In many NDA measurements for uranium and/or plutonium, the spectral shape and rates will be constant during a count interval. In segmented scans both rate and spectral shape will vary but the variation within a single segment will almost never produce a significant error in total result. What must be emphasized is that running a multichannel analyzer in a livetime mode *does not* correct for losses due to pulse pileup which may be just as significant.

The term "pulse pileup" refers in general to the fact that gamma-ray interactions which are separated (temporally) by less than the output pulse width of the main amplifier will produce a piled up or summed amplifier output. Roughly speaking, if the time between interactions is less than half the pulse width, the maximum pulse height will not correspond to either event, and neither

event will be recorded in the proper place in the MCA spectrum. A single event will be recorded at a spot in the spectrum corresponding to some fraction of the sum of the two independent events. The effects can be appreciable with germanium detectors where the full energy spectral peaks are narrow and the amplifier output pulse is often 10- to 20- μ s wide. Consider a system using an amplifier with unipolar shaping and 3- or 4- μ s time constants; this produces an output pulse whose width is $\sim 15 \mu$ s. At a gross rate of $\sim 10^4 \text{ s}^{-1}$ the fraction of events thrown out of a full energy peak is ~ 0.15 [$\sim (15 \times 10^{-6} \text{ s})(10^4 \text{ s}^{-1})$]. Thus $\sim 15\%$ of the full energy peak events would be lost over and above any loss due to deadtime. In general, even at gross rates of only a few thousand per second such losses will be a few percent.

The most direct way to minimize pileup losses is to use the shortest possible amplifier time constants consistent with the resolution required. If, for example, 1- μ s shaping is adequate, the pileup effects will be a factor of four less than with 4- μ s shaping.

The use of absorbers to selectively attenuate low energy gamma radiation while preserving most of the usable higher energy flux also helps reduce pileup and deadtime by reducing the gross rate in the detector. For most NDA measurements of plutonium and/or uranium no use is made of the copious x-ray emissions or, for plutonium, of the 60-keV gamma rays from ^{241}Am . When assaying ^{239}Pu by means of its 413.7-keV gamma ray, 1 to 2 mm of lead backed with 1 mm of cadmium greatly reduces the radiations below ~ 150 keV. Such selective filters will usually include a thin layer of high-Z (e.g., Pb or W) materials because they offer the best selective discrimination against low energy gamma rays.

6.2 Constant Rate Pulser Corrections

After doing what can be done to minimize the effects of pileup and deadtime, corrections should usually be made for residual effects which are still nontrivial. A common and effective method for making deadtime and pileup corrections is to insert a pulser peak into the spectrum through a

preamplifier input. If the pulser rate is reasonably low (typically 60 Hertz from a very stable mercury switch pulser), the losses from the pulser peak will be nearly the same as from other spectral peaks. Knowledge of the count time and pulser rate determines the expected pulser count in the absence of losses. Standard procedures give the actual area and the ratio of actual-to-predicted gives the fractional counting loss. Since the pulser is periodic and the gamma-ray events are random, the gamma-ray peaks will suffer slightly higher losses than the pulser peak. The factor by which the gamma-ray peak deadtime losses exceed the pulser peak deadtime losses is $\sim (1 + RT)$, where R is the pulser rate and T is the deadtime per pulse. Thus, for a 60-Hertz pulser and a combined system deadtime of $30 \mu\text{s}$ per pulse, the factor is ~ 1.002 , which may be ignored for most NDA work. The factor by which the gamma-ray peak pileup losses exceed the pulser peak pileup losses is $\sim (1 + R\tau)$, where R is the pulser rate and τ is the amplifier pulse width. This factor is generally smaller than the factor for deadtime because the amplifier pulse width is usually less than the MCA deadtime. The two correction factors just mentioned are usually small enough to be negligible in most practical cases, but it is good to be aware of the possibilities if it is casually de-

cidated to use a high pulser rate or a long ($\geq 100 \mu\text{s}$) MCA deadtime.

A note of caution is appropriate on the use of pulsers. It is often difficult to eliminate the undershoot from the amplified pulser pulses. If the amplified pulses have a long undershoot, even of small amplitude, it will cause excessive pileup losses and/or peak distortion. Effort should be taken to make the amplified pulser pulses nearly identical in shape to the amplified detector pulses. It is possible to add a pole-zero cancellation network to the preamplifier pulser input. Such a circuit is shown in Fig. 6.1. R_L is chosen to match the pulser output impedance, usually 93Ω or 50Ω . RC is chosen to match the pulser pulse decay time. R is chosen as large as practical ($\geq M\Omega$) to limit the degradation in system resolution. From a noise standpoint, R appears in parallel with the feedback resistor in the first stage of the preamplifier. It increases the resistance noise contribution and lowers the resolution. For example, if the pulse decay time is 10^{-3} s and R is chosen to be $10^9 \Omega$, C should be chosen as 1 pF. This should eliminate the pulser pulse undershoot with minimal resolution degradation.

6.3 Gamma-Ray Source Normalization

In some cases a better correction method is to use a gamma-ray source for deadtime and pileup

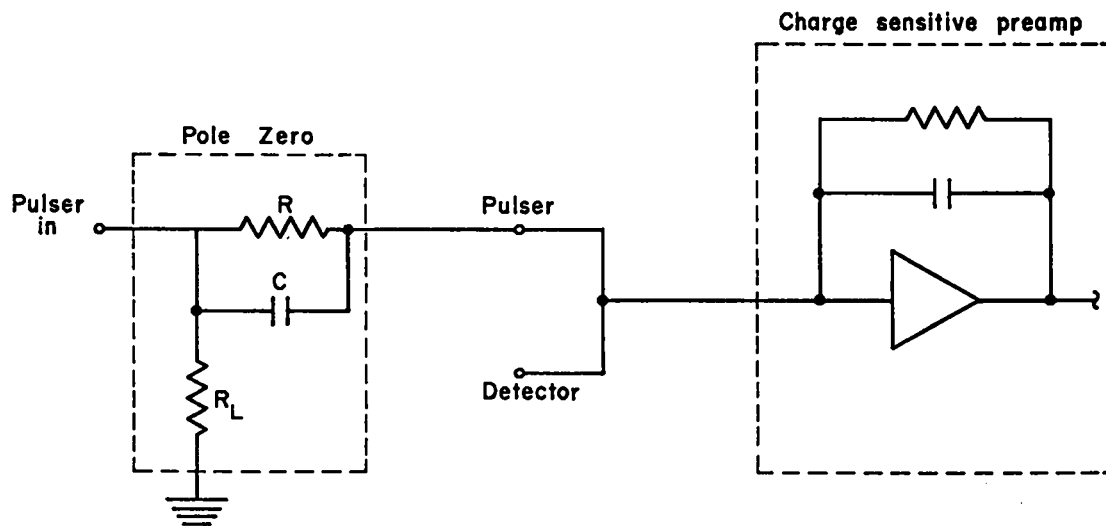

Fig. 6.1. A pole-zero cancellation circuit which can be added to the preamplifier pulser input to cancel the undershoot produced when using an external pulser to correct for system deadtime and pileup.

normalization. A suitable source is positioned so that the detector always sees a constant flux from the source. Before making measurements, the normalization rate R_0 (counts in chosen full energy peak per unit time) is determined with no sample in the assay position. For actual measurements, the full energy peak rate R of the normalization gamma ray is determined and all full energy peak areas of interest are multiplied by the ratio R_0/R . This procedure assumes that all spectral peaks will suffer the same fractional loss from pileup and deadtime.

The advantages in using a gamma-ray source are that there is no possibility of gain shifts for the correction peak relative to the rest of the spectrum, that the rate is easily varied, that no corrections need be made for the nonrandomness of a pulser, and that, in general, a source is simpler than a pulser. The disadvantages are the difficulty in finding a source of just the desired energy with a sufficiently long half-life and the general increase in rate due to Compton events and "extra" gamma rays.

6.4 Detector Generated Pulser

A third correction procedure is to use a fast discriminator on the preamplifier output, scale the discriminator pulses by a fixed factor, and use this to generate a pulse whose rate is proportional to the gross rate of the system. This pulse is then fed back into the preamplifier.^{6.4} The fed-back pulse is again subject to both pileup and deadtime. Comparing the number of pulses generated with the number appearing in the corresponding peak gives the desired correction. This procedure has an advantage over a fixed-rate pulser in that it gives correct results even if the rates vary during a count interval, as long as the spectral shape remains constant. The disadvantage is a more complex system. The considerations with respect to corrections for the nonrandomness of pulsers apply here.

The emphasis of this section is that both deadtime and pileup may easily be significant in NDA measurements and due care should be exercised to first minimize and then correct for both effects.

REFERENCES

- 6.1 R. D. Evans, *The Atomic Nucleus* (McGraw-Hill Book Co., Inc., New York, 1955), Chapter 28, pp. 785-827.
- 6.2 J. Harms, "Automatic Dead-Time Correction for Multichannel Pulse-Height Analyzers at Variable Counting Rates," *Nucl. Instrum. and Meth.* 53, 192 (1967).
- 6.3 P. Quittner, *Gamma Ray Spectroscopy* (Adam Hilger Ltd., London, 1972), Chapter 10, pp. 96-104.
- 6.4 H. H. Bolotin, M. G. Strauss, and D. A. McClure, "Simple Technique for Precise Determination of Counting Losses in Nuclear Pulse Processing Systems," *Nucl. Instrum. and Meth.* 83, 1-12 (1970).

7. ASSAY PROCEDURES

The procedures and equipment configuration adopted for a particular assay problem will depend on many factors. Among those factors will be the isotopes to be measured, the size and shape of the container, type and degree of homogeneity, required throughput, desired accuracy, and the available equipment. No attempt will be made to prescribe optimum procedures for every situation; rather a few general procedures applicable to a large fraction of probable assay problems will be discussed.

7.1 Transmission-Corrected Segmented Scanning

It is observed that in the process of filling scrap and waste containers vertical variations frequently occur in the volume densities of source and matrix materials. Radial inhomogeneities are less pronounced, and their effects can be substantially reduced by sample rotation. In such cases the container may be scanned as a vertical sequence of independent thin segments, each of which is assumed to be reasonably homogeneous.^{7.1} The differential measurements of uranium and/or plutonium activity and gamma-ray transmissions are obtained by scanning the rotating container and using detector collimation to define the segments. Combining transmission-determined correction factors on a segment-by-segment basis with the resolution of the Ge(Li) detector gives probably the best current method of doing gamma-ray assays of packages containing ≥ 10 g of ^{235}U or ^{239}Pu . It must be recognized that the advantages of the segmentation procedure are gained at the loss of some degree of sensitivity; hence a system employing segmentation would probably not be used on samples containing ≤ 1 g of ^{239}Pu or ^{235}U .

For a segmented, transmission-corrected gamma-ray assay the general spatial relationships of detector, collimator, assay sample, transmission source, and the pileup and deadtime normalization source are shown in Fig. 7.1. The specific arrangement shown is tailored to the assay of ^{239}Pu in cylindrical containers ≤ 20 cm in diameter. A rather detailed discussion of this assay problem, with comments concerning assay of other isotopes and package sizes, will suffice to illustrate the ideas and constraints involved.

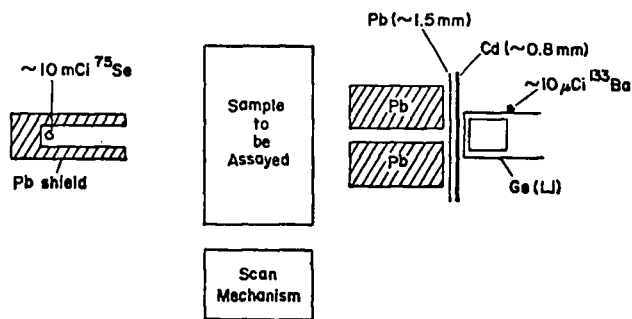

Fig. 7.1. General arrangements for segmented, transmission-corrected gamma-ray assay. The specific situation shown is tailored to the assay of ^{239}Pu in cylindrical containers ≤ 20 cm in diameter.

The sample container is positioned as close as possible to the collimator (the constraints are often bagging and/or container handles) to maximize count rates and give the best segment resolution. The "segments" overlap somewhat as determined by the sample size, collimator dimensions and their relative positions. For the case illustrated in Fig. 7.1 a collimator ~ 1.25 cm high and ~ 10 cm deep (often composed of two standard lead bricks properly spaced) provides a reasonable trade-off in sensitivity and spatial resolution. For 30- and 55-gal drums a collimator ~ 5 cm high and ~ 20 cm deep has been a reasonable choice. The spatial resolution of the segments cannot be as sharp in the latter case but it is still sufficient to provide useful information on the degree of uniformity of material distribution. The obvious choice of collimator material will usually be lead. If space is a consideration, a tungsten alloy may be used.

To maximize count rates the detector will be as close as possible to the collimator. For the plutonium measurement a filter of lead (~ 1.5 mm) and cadmium (~ 0.8 mm) serves to reduce the rate of low energy events from ^{241}Am and the x rays of both plutonium and lead. As discussed in Chapter 6, such filters are useful in reducing the effects of pileup and deadtime. The exact filter configuration will depend on the sample. For ^{235}U assay the cadmium alone should suffice, because there will not be the 60-keV ^{241}Am flux found in plutonium materials.

In this case of ^{239}Pu assay ^{75}Se is used as the transmission source because it gives the most accurate correction. Its 400-keV gamma ray is close in energy to the 414-keV gamma ray of ^{239}Pu . Since it is lower in energy, its Compton continuum does not significantly decrease the ^{239}Pu sensitivity as would the continuum from ^{137}Cs or ^{22}Na . A source strength of ~ 10 mCi should provide usable intensity for at least one year in spite of the short 120-day half-life of ^{75}Se . Position adjustment and judicious lead filtering are used to adjust the ^{75}Se count rate to the desired level. The transmission source itself should be encased in a collimator-shield to avoid undue personnel exposure.

The 356-keV gamma ray from the ^{133}Ba source is used for deadtime and pileup correction as well as for spectral stabilization. It has no gamma rays which interfere with either the 414-keV gamma ray of ^{239}Pu or the 400-keV gamma ray of ^{75}Se . The 10.4-y half-life is also convenient. A source of ~ 10 μCi is generally adequate and may be positioned right on the detector housing to give a proper rate. For the assay of different isotopes, other combinations of transmission source, correction source, and assay gamma ray will be necessary. Table 7.1 gives several useful combinations. It is possible (see Chapter 6) to use a pulser instead of the source, if one is available with adequate rate and stability.

Segmented scans may be accomplished in several ways, which may be divided under the general headings of discrete and continuous scans. In a discrete scan the sample is positioned, counted while fixed vertically, repositioned, counted again, etc. In a continuous scan the rotating sample moves with a constant speed past the collimator. The count dwell time is often chosen as the time required for the container to move the height of the collimator. Both methods would give acceptable results, and the decision of which to use might be based on hardware availability. The continuous scan scheme probably gives a better average transmission within segments. For the ^{239}Pu assay system shown in Fig. 7.1 the continuous mode is used with a vertical speed of ~ 0.127 cm/s (0.05 in./s) and a count dwell time of 10 s. The scan of a container 25 cm high takes ~ 200 seconds. All analysis and sample changing

TABLE 7.1
USEFUL COMBINATIONS OF SOURCES

Isotope Assayed	Transmission Source	Correction Source
^{238}Pu 766.4 keV	^{137}Cs 661.6 keV	^{133}Ba 356.3 keV
^{239}Pu 413.7 keV	^{75}Se 400.1 keV	^{133}Ba 356.3 keV
^{235}U 185.7 keV	^{169}Yb 177.2, 198.0 keV	^{57}Co 122.0 keV
^{238}U 1001.1 keV	^{54}Mn 834.8 keV	^{137}Cs 661.6 keV
^{237}Np 311.9 keV	^{203}Hg 279.2 keV	^{235}U 185.7 keV

might take another 100 s, so assays of 25-cm-tall containers might take 5 min each. The ^{133}Ba and ^{75}Se sources are generally adjusted to give $\sim 10^4$ counts/segment in the full-energy peaks of interest. For better precision or greater sensitivity the scan speed may be decreased if the longer assay time is acceptable. A compromise must be reached between precision and throughput.

In all segmented scans the computations are performed on a segment-by-segment basis using the appropriate correction factors and corrections for deadtime and pileup discussed previously. Appendix C lists the relevant assay equations and the appropriate counting precision equations for this situation.^{7.2}

7.2 Variations of Transmission-Correction Procedures

Numerous variations are possible to the procedures described above. Two such situations are commonly encountered and will be discussed.

If a category of scrap or waste exists which is a reasonably uniform mixture of matrix and material, and if the containers are filled to a known and constant depth, the segmentation may be eliminated. The detector can then be backed up far enough to reduce $1/r^2$ effects to an acceptable

level, and the transmission measured at a single location near the middle of the container. If the contents are uniformly distributed, the correction factor so determined will apply to the whole container. Such a system will generally have a better sensitivity than one using vertical collimation. The sample may also be scanned up and down over a fraction of its height and thus average the measured transmission over a larger fraction of the sample.

If the transmission gamma ray is higher in energy than the assay gamma ray, its Compton continuum will decrease both the precision and sensitivity of the assay peak measurement. Even if the assay gamma ray is of higher energy, pileup from low energy events can produce background under the assay peak. If the utmost sensitivity and precision is desired and a decrease in throughput is acceptable, an assay may be done in two scans. The container is first scanned with the transmission source to obtain applicable correction factors. Then the transmission source is shielded or removed and a scan is made of the assay gamma ray. In using ^{169}Yb (177 keV and 198 keV) as a transmission source for the assay of ^{235}U (186 keV) this two-scan scheme is particularly useful.

7.3 Differential Absorption Methods

The data acquisition procedures for differential absorption methods are quite simple. The possibilities and limitations of the method have been outlined above in Section 5.4 and in Appendix B. If the sample meets the necessary assumptions, the assay consists of acquiring a high resolution spectrum with sufficient activity in the required peaks to give the desired assay precision. As in other procedures, sample-to-detector distance will be a compromise between minimizing $1/r^2$ effects and maximizing count rate. Usual cautions must be observed with respect to minimization of and correction for deadtime and pulse pileup. The sample will probably be rotated but not scanned. Because of the simplicity of the data acquisition procedures, the method is attractive where there is a sufficient number of samples to which it clearly applies.

7.4 NaI Detector Procedures

The advantages and limitations of NaI detectors relative to Ge(Li) or intrinsic Ge detectors have been discussed previously. That discussion indicates that Ge(Li) or intrinsic Ge is preferred (ignoring factors of cost) except in cases where the potentially greater efficiency of NaI is required. The assay of large containers (e.g., 30- and 55-gal drums) of low-level waste is such a situation. Rapid screening wherein a fraction of items may be flagged for a more careful assay by other methods is also a common application.

Many of the ideas and principles in doing assays with high resolution detectors directly apply to the use of NaI. A few comments should be made on significant differences. Pulse pileup is not the problem with NaI that it is with Ge(Li). Much shorter amplifier time constants may be used with resulting output pulses as narrow as 1 μs full width. This reduces the problem of pileup and allows higher count rates. The wide windows used for peak area determinations also tend to reduce pileup effects. It must be noted, however, that, although the effect can be much smaller (5-10%) than in Ge(Li) detectors, it is more difficult to make corrections. The system is usually so set up to limit the count rates such that pileup may be ignored.

A last cautionary item concerns backgrounds and background subtractions. In any gamma ray assay, whether Ge(Li) or NaI, the detector should be carefully shielded. It should be possible to eliminate all contributions to the full-energy peaks of interest save from the sample being assayed. The only "background" remaining is the continuum under the full-energy peaks, and these are subtracted out by one of the usual methods. Background runs are not required if the detectors are properly shielded and if the assay is based on full-energy peak areas only. An occasional count to assure that the background peak areas are indeed zero is all that is necessary. Occasionally procedures are employed in which continuum subtraction is not used. In such cases backgrounds must be more carefully considered, as the continuums under full-energy peaks may be more easily changed than the actual peaks.

REFERENCES

7.1 J. L. Parker, T. D. Reilly, J. E. Foley, R. B. Walton, and L. V. East, "Passive Assay-- Innovations and Applications," Institute of Nuclear Materials Management Proceedings II, 514 (1971).

7.2 E. Ray Martin, David F. Jones, and L. G. Speir, "Passive Segmented Gamma Scan Operation Manual," Los Alamos Scientific Laboratory report LA-5652-M (1974).

8. TYPES OF ASSAY SYSTEMS

The assay systems (hardware and software) required to carry out a particular assay procedure will depend on the procedure and such factors as desired throughput, desired degree of automation, requirements for portability, and cost. A given type of assay can usually be done with various equipment configurations. Careful consideration should be given to the factors involved. A few system types will be mentioned here to illustrate the range of different configurations.

8.1 Computer-Based Ge(Li) System

A full scale transmission-corrected, segmented scan with a Ge(Li) detector requires the use of a computer or programmable calculator. In such a procedure there are too many data generated, and the computations are too complicated to do manual data reduction. With a computer a high degree of automation is achieved by letting the computer control the mechanical scan apparatus. At least two options are possible. The system can include a multichannel analyzer (MCA) controlled by the computer, or the analog-to-digital converter (ADC)

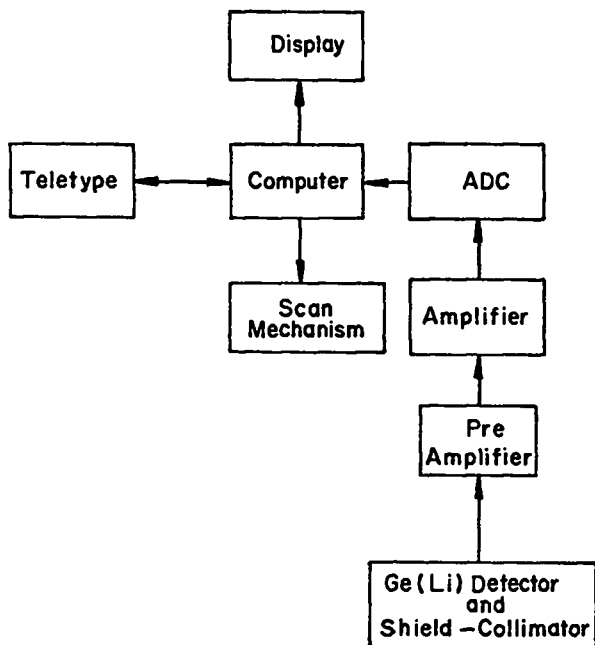

Fig. 8.1. Block diagram of computer-based gamma-ray assay system.

may be interfaced directly to the computer, which then performs the MCA functions. Figure 8.1 is a block diagram of a system employing the latter option. Figure 8.2 is a picture of such a system. The device pictured (and any other including the same functions) can do fully automated assays of containers up to standard 5-gal size. The vertical collimation (not pictured here) and sample-detector distances are varied to suit the container size.

8.2 MCA-Based Ge(Li) System

Many currently obtainable MCA units have a certain amount of hard-wired computational ability, including functions that integrate selected spectral regions or even do a simple background subtraction to give actual peak areas. If no segmentation is done, such an MCA would allow a transmission-corrected assay to be done with the aid of a desk calculator. Throughput will suffer and the chance of computational error will increase.

8.3 SCA-Based System

For some applications, a system based on NaI detectors with several SCAs set over spectral regions may suffice. Such systems are cheaper and

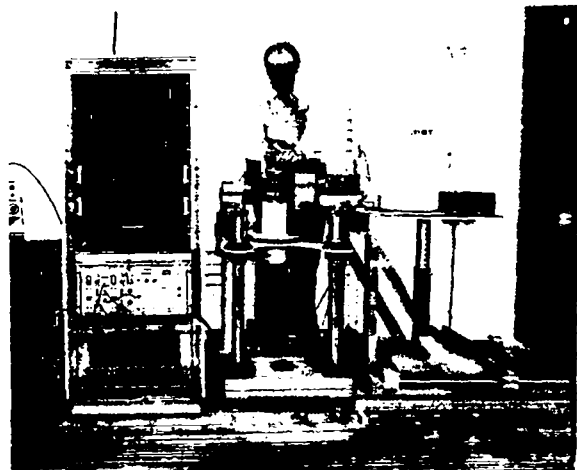

Fig. 8.2 Computer-based system capable of automated segmented assays of containers up to 5-gal size. The vertical collimation and sample-detector distance are varied to suit the container size.

simpler than those employing high-resolution detectors with computers and/or MCAs but will suffer numerous disadvantages with respect to throughput, data reduction, spectral interferences, etc. One real advantage of such systems is the possibility of actual portability. Systems composed of a

shielded NaI probe and battery-powered electronics exist and can be easily carried by one man. Data reduction can often be done with a pocket calculator. Such systems offer qualitative and even reasonably quantitative assay capability.

9. STANDARDS

All gamma-ray assays should be made relative to a standard which is representative of the material being measured. Consequently adequate standards are a very vital part of any assay system. A good general guide to NDA standards and calibration procedures is given in a recent American National Standard, ANSI N.15.20.^{9.1} This guide is recommended to potential users of gamma assay equipment. The standards essentially provide a measurement of the detector efficiency, the specific activity of the signature of interest, and the effects of sample geometry (size, shape, and sample-to-detector distance). In systems where a measured attenuation correction is not used, the standard is also expected to have the same attenuation as the unknown samples. This latter procedure is not recommended. In general terms the purpose of the standards is to define the calibration factor, K, in Eq. (1.1). Formally

$$K = \frac{CR_s \cdot CF_s}{M_s},$$

where

- K = calibration factor (counts/g of isotope of interest),
- M_s = known mass of emitting isotope,
- CR_s = measured count rate from the standard,
- CF_s = attenuation correction factor for the standard.

The following is a general discussion of the fabrication and use of gamma-assay standards.

Ideally the standard should be nearly identical to the unknown, but this is usually a fiction, particularly for the measurement of waste and scrap. A more reasonable criterion is that the standards have the same size and shape as the unknowns. In principle, it is possible to use different size standards and compute the effect of the different size on the standard response. Such computations are complicated if done correctly, and subject to large errors if not. In general, this approach is not recommended; nevertheless, it may be the only practical one for certain types of samples, particularly large and/or irregular shapes. Since standards are generally required for each different size sample, this should be a great incentive to

minimize the number of different size containers used in a given facility and in the industry as a whole (more on this in the next section).

The main effect of different matrix materials is to vary the sample attenuation. Uranium and plutonium are found in combination with a wide range of matrix materials (particularly in the scrap and waste categories). This is the crux of the problem with assay procedures which do not use a measured attenuation correction (external source transmission or differential absorption). For such procedures it is necessary to assume that the unknowns have the same matrix attenuation as the standards. There is no way to verify this assumption. There may be some categories of material where the attenuation does vary very little from sample to sample. Product materials such as fuel pins or plates are a good example. Here the assay is mainly to show a deviation from a mean (defined by the standard), and a measured attenuation correction is unnecessary in many cases. Such is obviously not the case for scrap and waste materials. The bulk density of most powders can be changed over a considerable range by agitation and vibration. The attenuation (and hence the measured sample gamma activity) of a container of incinerator ash can be changed significantly just by giving it a vigorous shaking, thus decreasing the bulk density of the contents. The matrix material (and its attenuation) will vary from sample to sample even within a single material category. Even if standards of different attenuation properties are available, there is no way to choose which attenuation to apply. Large measurement biases are almost always introduced when using procedures which do not have a measured attenuation correction. No matter how "representative" the standards are claimed to be, it is usually impossible to guarantee that the unknowns really have the same attenuation as the standards. Thus the use of a measured attenuation correction is strongly recommended.

The purpose of the attenuation correction (transmission or differential absorption) is to measure the degree to which the attenuation of the unknown differs from that of the standard. In principle, a single standard of each container size will

suffice if such a correction is used. This standard will define the calibration constant (counts/g), and the transmission or differential absorption measurement will evaluate the difference in attenuation from the unknown to the standard. In practice it is recommended that several standards be fabricated to span the expected range of attenuations and perhaps also the range of nuclear material loadings. The expected attenuation can easily be estimated using the expressions in Chapter 5 (do not forget the attenuation of the source material; for uranium standards the variation of attenuation and source loading are usually accomplished easily with several different uranium loadings). The minimum set would be two standards with attenuation and loading near the extremes expected in the unknowns. In most cases more would be desirable. This is necessary to check that the attenuation correction is being evaluated properly. This is to say, *all standards of a given size container should yield the same calibration factor (counts/g)*. The standards need not cover every expected matrix, only the different size containers. One way of covering the expected attenuations, however, may be to construct one standard in each of the expected matrix categories.

If transmission measurements are used, the assay is quite insensitive to the chemical composition of the matrix. The important parameter is the absorption coefficient of the material, and this is obtained from the transmission measurement. Thus it is not necessary to duplicate the actual matrix material in the standards (though this may sometimes be desirable when attempting to track down measurement biases). Consider, for example, the range of attenuations found in small containers (< 15 cm diam) of incinerator ash and other solid scrap residues (e.g., leached solids, sand-slag-crucible). There is a wide range of attenuations involved due to different materials and processes (incinerator ash from one plant may be quite different from that of other plants). This attenuation range ($CF_{414} \approx 1.2-3.0$) can be quite well covered by using matrices of diatomaceous earth, graphite powder, and fine-grained quartz or MgO sand [the MgO sand should be avoided if the standards are to be used for neutron coincidence counting also, due to the large (α, n) background

which will be generated by the magnesium]. Three standards, each with one of these materials, would fairly well cover the range of interest. The materials must be free of radioactive contamination and should be in the form of a fairly uniform powder.

The source material (uranium or plutonium) for the standards must be very well characterized both with regard to mass and isotopic composition. Any error in the standard masses will show up as a bias in all measurements made against that standard. For high accuracy standards, it may be desirable to use standard reference material from NBS. Usually this will be too expensive and not feasible. Uranium or plutonium oxide powder will probably be used for most standard fabrication. The oxide should be milled to a moderately fine (several microns or less) uniform powder and then well blended to assure homogeneity. Replicate samples should be submitted for elemental and isotopic analysis. If the replicate analyses do not agree, the material should not be used in standards preparation. Plutonium materials should also be analyzed for americium content. The preparation and analysis of the source material should be carefully documented and saved as part of the certification of the standards in which it is used.

The source and matrix material must now be combined. The uranium or plutonium oxide should be carefully weighed into the desired quantities for the standards. The weighing should be done to a relative accuracy of at least 0.1%. The matrix material should be weighed also; this need not be as accurate (1% is more than adequate). *The source and matrix materials must be carefully blended and homogenized to assure a uniform distribution in the calibration standards.* This point is very important and should be considered as the crucial goal throughout the design and fabrication of the standards. As has been explained in previous sections, nonuniform distribution introduces errors in gamma-ray measurements. Steps are always taken to minimize these effects (rotation, segmented scans, etc.). These will usually not eliminate such effects. Nonuniform calibration standards will usually lead to biases in the measurement system. Consider a large number of unknown samples. The distribution of material in any single container will usually show some degree of nonuniformity. This may be reflected

as an unknown error in the assay measurement. However, to first order it is reasonable to assume that the single container nonuniformities are randomly distributed throughout the inventory population of containers. If this is the case, the total inventory assay should be unbiased if the measurements are based on uniform standards. This argument, of course, is not strictly valid; however, all evidence to date seems to lend considerable credence to it. The fabrication of uniform calibration standards is very important.

Practically, the fabrication of uniform standards is often difficult. Consider standards of the type discussed above, e.g., PuO_2 plus graphite powder. These should be carefully blended before final sealing in the standard containers. If a vee-blender or other vessel is used, care must be exercised to see that all of the measured material is eventually transferred into the standard. Careful weighings should be conducted before and after blending to check for any loss of material. When the mixing vessel is cleaned, it may be desirable to assay the cleaning materials (using high sensitivity counting techniques) to verify that no material has been lost. The use of agitators or vibrators for mixing is not recommended as this seems to segregate rather than blend some mixtures of material. Powder mixtures may be expected to settle with time; the source material should be suspected of settling out of the mixture and altering the initial uniform distribution. Working standards should be scanned routinely (even if this is not the normal measurement procedure) to verify that this is not occurring. It is usually desirable to leave the standard containers not quite full so that they may be shaken from time to time to help maintain the uniform distribution of material. Most experience to date with the powder mixtures discussed above indicates that the settling and segregation is not a severe problem.

Other techniques for achieving uniform standards have been suggested and tried. Some of these involve putting the source material in solution, soaking the matrix in the solution, and then drying the combination. Several standards have been made at Los Alamos by drying plutonium nitrate solution on MgO sand. The process would seem to have merit but has not been completely satisfactory

in practice. It is necessary, beforehand, to determine the proper amount of acid which can be absorbed and dried uniformly on the matrix. An exact prescription cannot be given at present, but the technique deserves further development. The procedure has been used to simulate combustible waste. Wads of Kimwipes (sometimes shredded) and other paper and rag materials are lightly wetted with plutonium nitrate solutions and then dried and bagged. Extreme care must be taken to assure that all plutonium winds up in the standards and that the paper is well dried (otherwise, it wads up and assumes a density much different from normal combustible waste). This would seem to be a good procedure for making combustible waste standards (these are often large containers: 55-gal drums). The uniform mixture of oxide powder with Kimwipes and rags is very difficult. The filling process involves layers of shredded matrix very lightly sprinkled with source oxide. Even if done very carefully, it is difficult to prevent the oxide from settling out of the paper and forming oxide concentrations with significant self-absorption. For plutonium assays based on the 414-keV gamma (with its higher penetrability), this procedure can be used. General Electric has successfully fabricated mixed oxide waste standards using the oxide powder.^{9.2, 9.3} The procedure is strongly not recommended for uranium waste standards (for 186-keV assay). To illustrate this, an experience at Los Alamos should be cited. Natural and highly enriched uranium waste standards were fabricated as 1-gal bags to be loaded into a 30- or 55-gal drum. The procedure was to place a strong plastic bag in a 1-gal hospital dressing can. The desired quantity of U_3O_8 (individual bags had 1, 2, or 5 grams) was divided into 10 or more roughly equal portions. A thin layer of shredded Kimwipes was placed in the bottom of the bag and one of the oxide portions sprinkled on it. This was repeated until the oxide was all in and the bag full. As each new layer was added, it was compressed to hold the oxide in place. In spite of this, when the standards were carefully scanned and assayed for certification, it was found that they were unusable due to significant self-absorption in the oxide concentrations (lumps) which formed. Even one gram dispersed in the gallon bag showed nearly 20% micro-absorption which would not be corrected by

transmission measurements. Thus, this procedure for generating uranium waste standards is not recommended unless extreme care is taken to check the reliability of the finished standard.

Along these same lines, vials or sealed ampules have been used in some labs to contain the uranium or plutonium used in waste standards. A small quantity of uranium or plutonium oxide is sealed in the vial, and the vials are then distributed in the matrix to achieve the final standard. This makes future recovery of the source material easy and allows the fissile loading of the standard to be changed easily. *This procedure is strongly discouraged* due to the self-absorption within the source capsule.

Consider 1/2 g of uranium as UO_2 (bulk uranium density = 2 g/cm^3 , ignore attenuation in oxygen):

If contained in a cube, the dimension of that cube is

$$(0.5 \text{ g} / 2 \text{ g/cm}^3)^{\frac{1}{3}} = 0.63 \text{ cm}$$

$$U: \mu(186) = 1.5 \text{ cm}^2/\text{g}.$$

Using Eq. (5.2a),

$$\mu x = (1.5 \text{ cm}^2/\text{g})(2 \text{ g/cm}^3)(0.63 \text{ cm}) = 1.9 \quad ,$$

$$CF = \frac{1.9}{1 - e^{-1.9}} = 2.2 \quad .$$

That is, less than half of the 186-keV gamma rays will get out of this volume unattenuated. For PuO_2 , $\mu(414) = 0.26 \text{ cm}^2/\text{g}$, so this becomes

$$\mu x = (0.26)(2)(0.63) = 0.33 \quad ,$$

$$CF = 1.17 \quad .$$

Though the self-attenuation is smaller, it still represents a nonnegligible error which will show up as a bias (assay will be high) on all measurements. Furthermore, the self-attenuation of the vial will change as the source material shifts around in the vial. *Distributed vials of fissionable material should definitely not be used.*

After the standards are fabricated, they should be carefully measured to verify their contents. Uniformity of loading can be checked by careful segmented gamma scans and by radiography. The fissile contents should be measured to check for consistency with other similar gamma standards. If other assay techniques are available (neutron coincidence counting, active delayed neutron assay,

neutron source activation techniques, etc.) which can measure this material, the standards should be measured with these also. Plutonium standards are readily amenable to calorimetric assay if reliable isotopic and americium data are available (as they should be for the standards). It may also be valuable to set up exchange programs with other NDA laboratories to further build confidence in the counting standards used throughout the industry. In the long run it may be desirable to have reference counting standards (in selected container sizes and categories) made available through some national agency.

The discussion so far has pertained to calibration standards used for determining the response per gram of the assay system. Some of these would also become working standards used for the day-to-day calibration and check of system operation. Routine procedures are needed to assure that the system calibration remains constant. An outline of such measurement quality assurance programs is given in the ANSI standard referred to earlier.^{9.1} In addition to these it may be necessary to fabricate additional standards to document the limit of error of the system. The major errors in a gamma assay system arise from nonuniform distributions of material. This may include source material, matrix material, variation with respect to density alone, or variations of elemental and even isotopic concentration. Estimates of the degree of this variation can be made computationally by analyzing the effect of loading variations on attenuation and counting efficiency. It may also be desirable to fabricate some nonuniform standards and measure the effect of such distributions on the system. For this a useful approach is to build a modular system of standards with small individual standards which may be arranged in different configurations in the larger standard container. The individual modules are usually made as uniform standards but with a variety of matrices and source loadings. They can then be loaded in the main container and counted to test the effect of various nonuniform distributions on the system performance. The Rocky Flats plant of the Dow Chemical Company has used such a modular set of standards for many years.^{9.4} Such studies are probably not feasible for every plant, but rather some criteria should be developed at the larger facilities and the national laboratories (this would be

much easier to develop if there were some industry-wide standardization on material segregation and packaging).

REFERENCES

9.1 American National Standard, ANSI N.15.20, Guide to Calibrating Nondestructive Assay Systems. Sections of particular interest include 5.4--sources of NDA error (pp. 5.7-5.15), 6-- physical standards (pp. 6.1-6.6), and A.4--passive gamma-ray methods (pp. A.8-A.12).

9.2 Handbook of Mixed Plutonium-Uranium Oxide Nondestructive Assay Reference Standards, General

Electric Company internal report, to be published; copies should be available from D. M. Bishop, GE Vallecitos Nuclear Center.

9.3 J. L. Parker and T. D. Reilly, Los Alamos Scientific Laboratory report LA-5197-PR (1972), pp. 14-15. This article describes measurements made on the waste standards of Ref. 9.2.

9.4 L. W. Doherty and J. D. McBride, "A Control Design for Plutonium Counting Systems," Proceedings of the Eleventh Annual Meeting of the INMM, May, 1970, pp. 71-84.

10. PACKAGING

Gamma-ray assay systems are more affected by variations in sample size and packaging procedures than are other NDA techniques. Calibration factors (K) change with size as do some other system parameters, such as collimation and source-to-detector distance. The accuracy and reliability of gamma-ray assay is much improved if all materials are measured in the same size container (or a very limited number of different size containers). This minimizes the number of standards required (each different size requires different standards).

Material for gamma-ray assay should be packaged in small containers to minimize gamma attenuation. The important dimension is the container diameter as this determines the magnitude of the absorption. In general, a higher measurement accuracy is obtainable on smaller diameter containers. The effect of container diameter is illustrated in Table 10.1. The numbers in this table assume the following parameters:

(1) Matrix attenuation coefficient (low Z, ≤ 20):

$$\mu_{186} = 0.13 \text{ cm}^2/\text{g}$$

$$\mu_{414} = 0.095 \text{ cm}^2/\text{g}$$

(2) Matrix density: 1.0 g/cm^2 (many powder scrap residues such as ash, sand-slag-crucible, leached solids, etc., have a bulk density in the range $0.5\text{--}1.5 \text{ g/cm}^2$).

(3) Source (uranium or plutonium) attenuation coefficient:

$$\mu_{186} = 1.5 \text{ cm}^2/\text{g}$$

$$\mu_{414} = 0.25 \text{ cm}^2/\text{g}$$

(4) The maximum total attenuation correction factor (CF) consistent with reliable routine assay is about 4.0. This corresponds to a transmission across the can diameter of less than 1.0%. Gamma assays can be made with correction factors of 5.0 (transmission about 0.2%) or higher; but these are difficult, require great care, and should not be made as a part of a routine assay procedure.

(5) The columns CF_{186} and CF_{414} give the correction factor for the matrix alone (no uranium or

TABLE 10.1
EFFECT OF PACKAGE SIZE ON GAMMA-RAY ATTENUATION

Diameter (cm)	Matrix Only		$\frac{\rho_U^a}{\text{g/cm}^3\text{-U}}$	$\frac{\rho_{Pu}^b}{\text{g/cm}^3\text{-Pu}}$
	CF_{186}	CF_{414}		
2-liter poly bottle				
10	1.61	1.43	0.18 (360 g)	1.3 (2600 g)
15	1.98	1.68		
1-gal hospital can				
20	2.38	1.95	0.05 (190 g)	0.4 (1500 g)
25	2.81	2.23		
5-gal bucket				
30	3.26	2.54	0.01 (190 g)	0.16 (3000 g)
55-gal drum				
60	6.25	4.61	0	0

^a This is the maximum uranium content consistent with the criterion $CF \leq 4.0$. The first number is the uranium density in g/cm^3 . The second is the uranium content in g, assuming a full container. The assay energy is 186 keV.

^b This is the maximum plutonium content consistent with the $CF \leq 4.0$ limit. The assay energy is 414 keV.

plutonium). The last two columns give the maximum uranium or plutonium concentration that could be uniformly distributed in the matrix without exceeding the 4.0 limit on the correction factor. The numbers in parentheses are the approximate gram weights of uranium or plutonium that these densities would give in the listed container volume.

Table 10.1 shows the obvious advantage of smaller containers for gamma-ray assay. Remember the possibility of measurement error increases with increasing CF. For combustible waste, the bulk matrix density is usually in the range 0.1-0.2 g/cm³ so the matrix attenuation is lower. In principle, 1000 g of uranium or plutonium if uniformly distributed in a 55-gal drum of 0.2 g/cm³ waste would not exceed the CF \leq 4.0 limit. However, at this level a uniform distribution is most unlikely and large systematic errors should be expected.

It is desirable to standardize packaging throughout the industry to facilitate the verification of shipments and receipts. The goal is to have a minimum number of container types in use throughout the nuclear industry. The following are suggested package types:

- 2-liter plastic bottle (uranium or plutonium scrap),
- 1-gal can (plutonium scrap, not recommended for uranium gamma assay if > 150 g uranium),
- 5-gal bucket (uranium or plutonium waste),
- 30- or 55-gal drum (uranium or plutonium combustible waste).

Any one plant should require only two container sizes, one for recoverable scrap and the other for lower-level waste. Regulatory Guide 5.11^{10.1} gives guidelines for scrap and waste containers (diameters less than 13 cm, waste to be placed in small cans before loading into drums). The guidelines stated there will certainly satisfy requirements for gamma assay. If drums are loaded with smaller packages, it is more accurate to measure the individual packages.

Strict segregation practices are necessary to maximize the accuracy of gamma-assay systems. Certain categories of waste and scrap should be defined on the basis of the material's amenability to gamma assay. The categories should be carefully observed. This applies particularly to large waste containers. A few rusty nails, nuts, or bolts in a small can of incinerator ash do not greatly affect the assay accuracy. A lathe bed in a drum of combustible waste will undoubtedly lead to an incorrect assay. When large containers are used for waste storage, strict administrative control is required to specify what may be put in the containers.

REFERENCE

- 10.1 USAEC Regulatory Guide 5.11, Nondestructive Assay of Special Nuclear Material Contained in Scrap and Waste.

11. MATERIAL CATEGORIES--PRECISION AND ACCURACY

It would not be possible or useful to discuss all the specific types of material which are encountered in the nuclear industry. They do, however, fall in some general categories, and this section gives a brief discussion of the accuracy which can be obtained on types which are amenable to gamma-ray accuracy. This information is presented in Table 11.1. The sensitivity estimate given in the table is based on a 1000-s count of the sample with an uncollimated Ge(Li) detector in fairly close coupled geometry. This is not meant to indicate the sensitivity that can be achieved with special low-level counting systems optimized for sensitivity. The assay systems discussed in this report are not designed for measuring very low-level waste. Most segmented scan systems have an effective sensitivity of about one gram of uranium or plutonium.

The precision of gamma-ray measurements needs little discussion. Typically it will approach the limit set by counting statistics. A valuable test for the operation of a gamma-assay system is to check that the measurement precision as determined by repeated measurements is consistent with that which is predicted by the propagation of Poisson counting statistics through the assay equations. For most situations considered here, the count rates are sufficiently high that the resulting precision should be 5% or better. All measurement results should include an estimate of the precision.

Table 11.1 illustrates a good point: combustible waste is best measured after it has been incinerated (changed to ash) and counted in small containers. In general, it is difficult to determine the accuracy of any scrap and waste measurement system since there is no reliable method of determining the actual contents of a real sample. Several procedures are used to investigate this, but the amount of experience to date is still rather small. Some of these approaches are listed below.

(1) A range of standards is fabricated to attempt to test the performance extremes of the assay system. (This was discussed in Chapter 9.)

(2) Plutonium samples can be calorimetered. If accurate isotopic and americium data can be obtained, this can give a good measurement of plutonium in small samples.

(3) Large combustible waste samples are incinerated, and the resulting ash can be measured quite accurately (by gamma techniques) and compared with the large container assay.

(4) The contents of a sample container can be split up and put in a number of smaller containers which can then be assayed more accurately for comparison with the initial assay.

(5) Chemical recovery is attempted of entire samples to determine the contained source material. This is often a very difficult process and should be followed very closely. All residues should be checked by gamma assay for possible uranium or plutonium.

TABLE 11.1
TYPICAL ACCURACIES FOR GAMMA ASSAY OF
CERTAIN MATERIAL TYPES

<u>Category</u>	<u>Relative Accuracy (2σ)</u>	<u>Sensitivity (g Pu or U)</u>
Combustible Waste (55-gal)	20%	100 mg
Powder Scrap Residue, e.g., ash (2-liter)	5%	1 mg
Solution Sample (2-liter)	1%	1 mg
Product or Rich Scrap (2-liter)	5%	--

The data in Table 11.1 summarize experience gained from experiments with most of the listed procedures. These experiments are really just beginning, and many more data are required to define NDA measure-

ment accuracy. Some experiments may need to be done by every NDA laboratory, but eventually it should be possible for new facilities to just cite the accuracy experiments conducted at other related plants.

APPENDIX A

PLUTONIUM ISOTOPIC DISTRIBUTIONS BY GAMMA-RAY SPECTROSCOPY

1. Background

In the body of this paper the emphasis with respect to plutonium assay has been on the determination of ^{239}Pu . The reason is twofold. First, most plutonium currently in use is $\geq 75\%$ ^{239}Pu , and it is usually preferable to assay the most abundant isotope. Second, the relatively high energy 413.7-keV gamma ray from ^{239}Pu is emitted at a rate of $\sim 3.5 \times 10^4 \text{ s}^{-1} \cdot \text{g}^{-1}$, allowing quite sensitive and accurate assays of the ^{239}Pu in many cases. Obviously difficulty arises when comparing a gamma-ray assay for ^{239}Pu with a chemical assay for total plutonium, in that the isotopic fraction of ^{239}Pu must be known in order to make the comparison. Sometimes the assayed samples are from a source with known or constant isotopic values but often no such knowledge is available, and experience has shown that assumptions of isotopic are all too frequently incorrect. It is true, of course, that any NDA measurement which is specific to a single isotope (or in some cases a small group of isotopes) suffers from the same difficulty of interpretation. A mass spectrometer isotopic analysis solves the problem but is often not feasible or desirable on the basis of time and cost.

For the present problem of interpreting quantitative gamma-ray assays of ^{239}Pu , it would be desirable to be able to determine the isotopic fraction of ^{239}Pu by gamma-ray spectroscopy. For other purposes, notably the interpretation of calorimetric measurements of the thermal power produced by a plutonium sample, it would be very useful to be able to determine the whole isotopic distribution including the ^{241}Am content by a gamma-ray measurement. With varying degrees of precision and accuracy it is currently possible to obtain a good deal of isotopic information from gamma-ray spectroscopy. Only in a few special cases does the accuracy of such NDA determinations approach that of destructive analysis based on mass and alpha-ray spectrometry. However, the NDA measurement may often be adequate and preferred on a cost

basis, and therefore it seems worthwhile to include here some discussion of the current status of measurement of plutonium isotopic fractions by gamma-ray spectroscopy. The gamma measurement may be used as a verification of the plutonium isotopic analysis.

2. Current Status

Within the general problem area of determining plutonium isotopic distributions by passive gamma-ray spectroscopy there are perhaps ten different cases and situations each requiring a somewhat different approach. As of this writing (December, 1974) only a few of the cases have really been solved in the sense of having been thoroughly investigated and equipment and procedures set up to operate reliably on a routine basis. The two best worked-out cases are those of low concentration solutions (few grams plutonium per liter) and the "enrichment meter" cases in solids.^{A.1, A.2} Work on almost all of the cases of interest is now being pushed at several laboratories and within a year a considerably better picture of capabilities and limitations of the technique to the various cases should be available.

Probably the most difficult problem is that of the arbitrary package of plutonium waste or scrap, uncontrolled and/or unknown with respect to size, shape, matrix, mass of plutonium and packaging material. This problem is, of course, precisely the one usually faced in interpreting NDA assays of plutonium scrap and waste based on the quantitative measurement of the ^{239}Pu . Some encouraging but preliminary results have been obtained in the problem of the "arbitrary package" and further work is in progress. The balance of this appendix will be devoted to procedures being investigated at LASL.

3. Generalized Method Applicable to Scrap and Waste

3.1 Assumptions and Signatures

3.1.1 *Necessary Assumptions.* The problem is attacked here in its most general form. Only two

assumptions need be made. The first assumption that will be made is that the isotopic distribution is constant throughout the volume of the sample. This assumption is necessary because in many samples the effective volume "sampled" by the escaping gamma rays will vary strongly with the energy of the gamma ray. The second is that a measurable flux of gamma rays is emitted at energies ≥ 120 keV, for the scheme described will depend only on gamma rays whose energy is ≥ 120 keV. Subject to the two requirements just given the sample may be of any size or shape and of any chemical composition. The discussion is confined to samples containing only plutonium and its daughters, although with some adjustments the scheme would work on plutonium-uranium mixtures. A certain amount of extraneous activities from fission products could be tolerated but with increased difficulty.

3.1.2 Useful Gamma Rays. The total number of gamma rays emitted by the $^{238,239,240,241}\text{Pu}$ and ^{241}Am is large (several hundred total). The best current complete compilation of energies and intensities is that of R. Gunnink (see Ref. 2.3). The short list in Table A.1 is excerpted from Gunnink's report and includes most of those gamma rays with energies ≥ 120 keV useful in determining isotopic ratios and/or relative counting efficiencies. All the energies are accurate to less than 0.1 keV, but the intensities of some of the weaker gamma rays are known to be somewhat in error (work is in progress on improved values). The intensities are given here as a qualitative guide to the possible usefulness of a particular gamma ray. Two comments are in order. The first is that the ^{242}Pu emits no gamma rays and, therefore, cannot be included directly in any gamma-ray measurement of isotopic distribution. The second is with respect to the gamma rays labeled ^{241}Pu (^{237}U). Those are actually emitted by the ^{237}U daughter of ^{241}Pu . Inasmuch as ^{237}U has a 6.75-d half-life, the activities will come into equilibrium in about a month, after which the gamma rays may be used as a measure of ^{241}Pu .

3.2 General Ideas and Technical Considerations

3.2.1 Isotopic Ratios Are Quantities Measured. In general, the total amount of each isotope in the

sample cannot be measured quantitatively, but ratios of the isotopic masses can be determined. These are, of course, the same as the ratios of the isotopic fractions. In principle, three ratios involving the isotopes $^{238,239,240,241}\text{Pu}$ are sufficient to determine their relative isotopic abundances. If the isotopic fraction of ^{242}Pu is negligibly small the relative isotopics will be very close to the actual isotopic mass fractions. If the ^{242}Pu fraction can be estimated reasonably well, the estimated ^{242}Pu may be included when normalizing the sum of the mass fractions to one. It must, nevertheless, be repeated as a fundamental limitation (though often not a serious one) that there is no way of directly determining ^{242}Pu by passive gamma-ray spectroscopy.

Calibration could be accomplished in two ways, either by comparison with standards of known

TABLE A.1
GAMMA RAYS USEFUL IN ISOTOPIC DETERMINATIONS

Isotope	Half-Life	Energy (keV)	Intensity $\gamma, s/dis$
^{238}Pu	87.78 y	152.8	1.01×10^{-5}
		766.4	2.40×10^{-7}
^{239}Pu	24 082 y	129.3	6.20×10^{-5}
		144.2	2.86×10^{-6}
		161.5	1.30×10^{-6}
		171.3	1.09×10^{-7}
		179.2	6.39×10^{-7}
		189.3	7.76×10^{-7}
		195.7	1.07×10^{-6}
		203.5	5.60×10^{-7}
		255.3	8.03×10^{-7}
		297.4	5.00×10^{-6}
		345.0	5.61×10^{-6}
		375.0	1.58×10^{-5}
		413.7	1.51×10^{-5}
646.0	1.45×10^{-7}		
^{240}Pu	6537 y	160.35	4.20×10^{-6}
		642.3	1.45×10^{-8}
		687.6	3.70×10^{-8}
^{241}Pu	14.35 y	148.6	1.90×10^{-6}
		160.0	6.45×10^{-8}
^{241}Pu (^{237}U)	14.35 y	164.6	4.50×10^{-7}
		208.0	5.12×10^{-6}
		267.5	1.77×10^{-7}
		332.3	2.80×10^{-7}
^{241}Am	434.1 y	125.3	3.95×10^{-3}
		169.6	1.68×10^{-6}
		662.4	3.46×10^{-6}

isotopic composition or by use of the fundamental data on half-lives and gamma-ray intensities. There is still enough uncertainty in some of the half-life and intensity data that the first procedure is recommended for routine use although the fundamental data are of extreme usefulness in predicting possibilities and probably performance.

3.2.2 Relative Detection Efficiency. Because both the sample self-attenuation and the detector efficiency vary with energy, the overall relative efficiency for the detection of gamma rays from a particular sample using a given detector is a strong function of energy. Although the detector efficiency curve may be quite well measured, the attenuation effects of an arbitrary unknown package of "junk" are most often impossible to predict. As a result the overall relative efficiency curve as a function of energy is often impossible to predict for given unknown sample-detector combinations. Let it be emphasized that the discussion here is with respect to samples of arbitrary shape, size, mass, and chemical composition. In cases with well defined geometry and known chemical composition, the effects of sample self-attenuation can in fact be accurately and usefully predicted.

Because of the recognized but often unknown variation of relative detection efficiency, it is customary and prudent to use gamma rays as close together in energy as possible in measuring isotopic ratios. The use of the 203.5-keV (^{239}Pu) and 208.0-keV (^{241}Pu - ^{237}U) gamma rays in determining the $^{241}\text{Pu}/^{239}\text{Pu}$ ratio is a typical example. Most often, if the relative efficiency changes could not be directly calculated over the range 5-10 keV, they have been ignored. If good results are desired, however, the relative efficiency changes cannot be ignored for the rate of change may vary between $\pm 1\%$ /keV between 100 and 400 keV. Furthermore, the shape of the relative efficiency curve will radically vary with size, shape, and composition of the sample. External absorbers can change the shape considerably.

Fortunately it is usually possible to construct a reasonably good curve of relative detection efficiency versus energy based on the known relative intensities of the gamma rays of ^{239}Pu . Referring to Table A.1 it is seen that ^{239}Pu has 13 gamma rays

between 129 and 414 keV. Some are weak and suffer interferences from other isotopes but, nevertheless, useful information may be extracted. The five gamma rays from ^{241}Pu may also be used to supplement and improve the information gained from the ^{239}Pu gamma rays. Finally it should be emphasized that once a curve of relative efficiency is constructed, gamma-ray pairs widely separated in energy may be used in determining isotopic ratios.

3.2.3 Americium Corrections. As before-mentioned the gamma rays from the ^{237}U daughter of ^{241}Pu are only useful in determining the ^{241}Pu fraction after equilibrium is reached between the two isotopes. Another correction must be made before the ^{237}U gamma rays can be used with confidence, namely, for the contribution of the ^{241}Am daughter of ^{241}Pu to the gamma-ray activity. Both ^{237}U and ^{241}Am populate excited levels of the ^{237}Np nucleus on decay and hence give rise to the same gamma rays although with different relative intensities. The half-life and intensity relationships are such that even when ^{241}Pu and ^{241}Am are equal in mass, the ^{241}Am contributions to the gamma rays of interest (mainly 164.6, 208.0, 267.5, and 332.3 keV) are only a few percent. Nevertheless, if more than four years have elapsed since the ^{241}Am was removed, corrections should be made. The correction for americium can be made by first determining the intensity of the ^{241}Am gamma rays to determine the ^{241}Am contributions for the gamma rays of interest. There are other approaches to the correction problem. What is emphasized here is the necessity of the correction if good results are desired.

3.2.4 Rate-Related Errors. Two types of errors may result from high count rates, both due directly or indirectly to the loss of events from the full-energy spectral peaks by pulse pileup. The first difficulty results directly from storage of the piled-up pulses. If the intensities of the 60-keV ^{241}Am peak and the x-ray peaks in the 90- to 120-keV region are allowed to be much higher than those of some of the peaks in the 120- to 200-keV region upon which the isotopic assay is based, the piled-up pulses can cause "bumpy" background continuums under the weaker assay peaks increasing the error in the measured area of those peaks. The intensity of the

low-energy gamma rays can be reduced by judicious selective filtering. Electronic pileup rejection may also be profitably employed to avoid storage of piled-up events.

The second type error arises from unequal pileup losses to the various spectral peaks. In cases where the main amplifier pulses are $\geq 10 \mu\text{s}$ (as will be the case with most high-resolution systems) pileup may affect a substantial fraction of events. As indicated in Chapter 6, that fraction is given roughly by $f = RT$ where $R =$ gross rate of detected events and $T =$ the pulse width. If, for example, $R = 5 \times 10^3 \text{ s}^{-1}$ and $T = 20 \times 10^{-6} \text{ s}$, $f \sim 0.1$, implying that about 10% of all events will be distorted to some extent by pileup. As shown in Chapter 6, peaks of considerably different intensity will usually suffer different pileup losses. The relations given there will show what the limitations on rate must be in order to ignore the effect.

The purpose here is not to give a full discussion of how either problem is minimized or eliminated but simply to point out a pair of problems which could have a measurable effect on isotopic determinations.

3.2.5 Peak Area Determinations. Accurately determining the relevant full-energy peak areas is crucial to any sort of quantitative gamma-ray measurement; the problem of isotopic determinations is no exception. If the peaks of interest are well resolved, satisfactory results may be obtained by one of the simple methods described in Chapter 4. If the peaks are not well resolved then recourse must be had to one of the good peak fitting codes. The isotopic analysis of plutonium falls very nearly in between cases. With a detector of the best resolution, reasonably good results are obtained by the simple methods. Nevertheless, as the americium concentration grows, a number of the multitude of ^{241}Am peaks come above the background continuum in awkward places, requiring great care in the selection of background windows for the plutonium peaks. Although efforts are still in progress to see just how well the simple methods can be made to work, it is clear that the best results will be obtained, especially in difficult situations, by more sophisticated peak fitting procedures. Systems have been

built consisting of a small computer processor with additional disk storage which are fully capable of doing a whole analysis including the least-squares fitting routines. Such a system would probably be desired and justified for doing routine isotopic assays by gamma-ray spectroscopy.

3.2.6 Isotopic Verification. In some situations it may be desirable to just verify that an assumed isotopic distribution is correct. In such instances an accurate measurement is often not required and many of the above considerations can be ignored. A single intensity ratio may give a sufficiently reliable check. The $^{241}\text{Pu}/^{239}\text{Pu}$ ratio is probably best for such checks (208 keV/203.5 keV if ^{237}U in equilibrium or 148.6 keV/129.3 keV if not in equilibrium). Relatively small changes in the ^{239}Pu concentration will be accompanied by large changes in the ^{241}Pu concentration so this is a good check of ^{239}Pu concentration. If the scrap and waste assay system includes a multichannel analyzer and computer, one of these line ratios should be checked routinely to assure that the assumed ^{239}Pu concentration is correct.

3.3 Determination of Isotopic Ratios

This section will be devoted to a qualitative discussion of the possible ways of determining specific isotopic ratios, along with some comment on the advantages and disadvantages.

3.3.1 Ratio $^{241}\text{Pu}/^{239}\text{Pu}$. Over quite a wide range of isotopic fractions, the 203.5-keV gamma ray from ^{239}Pu and the 208.0-keV gamma ray from the ^{237}U daughter of ^{241}Pu form a convenient pair by which to determine the $^{241}\text{Pu}/^{239}\text{Pu}$ ratio. Of course, there must be assurance that the ^{237}U is in equilibrium with the parent ^{241}Pu . Then correction should be made for the ^{241}Am contribution to the 208-keV peak and for the difference in relative detection efficiency.

An alternative pair is the 129.3-keV gamma ray from ^{239}Pu and the 148.6-keV gamma ray from ^{241}Pu . In this case there is no worry about equilibrium or americium contribution, for the 148.6-keV photons are directly from ^{241}Pu . On the other hand, because of the much larger energy difference (19.3 keV

vs 4.5 keV) the correction for relative detection efficiency must be made very carefully.

Other possibilities exist but the two cited seem the most promising. It appears that the $^{241}\text{Pu}/^{239}\text{Pu}$ ratio can be determined with an accuracy of $\pm 1\%$ (one sigma) if care is exercised. Let it be mentioned once more that here the discussion is about arbitrary "junk", not prepared samples of known geometry and composition where better accuracy may be obtained.

3.3.2 Ratio $^{238}\text{Pu}/^{241}\text{Pu}$. In most cases the 152.8-keV gamma ray of ^{238}Pu will be the one with energy ≥ 120 keV that must be used. Because of its proximity to the 148.6-keV gamma ray of ^{241}Pu , it is reasonable to measure that ratio. A ratio of the 144.2-keV gamma ray of ^{239}Pu to the 152.8-keV gamma ray might be taken for a $^{238}\text{Pu}/^{239}\text{Pu}$ ratio, but usually the area of the 144.2-keV gamma ray cannot be determined with sufficient precision. In material with low ^{238}Pu isotopic fraction ($\sim 0.01\%$) the determination of the $^{238}\text{Pu}/^{241}\text{Pu}$ ratio may not be better than $\sim \pm 10\%$ because of the very bad signal-to-background ratio the peak of the ^{238}Pu will have. As the fraction of ^{238}Pu increases, the accuracy of the determined ratio will improve; so that by the time the ^{238}Pu fraction reaches 1%, the accuracy of the $^{238}\text{Pu}/^{241}\text{Pu}$ ratio may well be $\pm 1\%$ at one sigma. As usual, care must be taken with relative efficiency corrections and the possibility of interference from weak ^{241}Am gamma rays.

3.3.3 Ratio $^{240}\text{Pu}/^{239}\text{Pu}$. This ratio is probably the most difficult overall to measure of any that must be determined. Two approaches may be used employing gamma rays with energies ≥ 120 keV.

The first employs the 642.3-keV gamma ray of ^{240}Pu and the 646.0-keV gamma ray of ^{239}Pu . There are also several ^{241}Am gamma rays in the region which make it difficult to get the peak area by simple background subtraction methods if the americium level is appreciable. The main difficulty in using this pair of gamma rays is their very low intensities. Long counts will surely be required, and if there is any fission product activity in the material the whole region may sink into the background.

The second possible energy region is the 160- to 164-keV region including the 160.3-keV gamma ray of ^{240}Pu . The difficulties here include the 160.0-keV gamma ray of ^{241}Pu which cannot be resolved, low intensities, and the possibility of pulse pileup creating irregular backgrounds under the peaks of interest. By using due care in both spectrum acquisition and analysis, results can be obtained but perhaps a 1 σ accuracy of $\pm 5\%$ is the best that could be extracted from the 160-keV region for the $^{240}\text{Pu}/^{239}\text{Pu}$ ratio. If it is free of extraneous activities and the count is sufficiently long, somewhat better accuracy can be expected from the 640-keV region.

3.3.4 Ratio $^{241}\text{Am}/^{239}\text{Pu}$. As before-mentioned; if it is desired to interpret calorimetric measurements of plutonium, it is necessary to determine the ratio of ^{241}Am to the plutonium. Several approaches are available.

The 125.3-keV gamma ray of ^{241}Am and the 129.3-keV gamma ray of ^{239}Pu have proven a useful pair. A slight difficulty, especially at low concentrations, is that there are two weak ^{239}Pu gamma rays (125.2 keV and 124.5 keV) which interfere with the ^{241}Am gamma ray and whose influence must be subtracted out. Attention must as usual be paid to relative detection efficiency corrections which may be as much as 10% over the 4-keV span of energy. For ^{241}Am concentrations ≥ 500 ppm ($^{241}\text{Am}/\text{Pu}$), precisions of a few percent should be attainable.

If the region at 640 keV is being used to determine the $^{240}\text{Pu}/^{239}\text{Pu}$ ratio the $^{241}\text{Am}/^{239}\text{Pu}$ ratio could also be determined by including the 662.4-keV ^{241}Am gamma ray, although it is likely that real peak fitting procedures would have to be applied to extract the 662.4-keV peak area.

As a third possibility a group of gamma rays between 332.3 and 345.0 keV can be used. The 332.3- and 335.4-keV gamma rays arise from both ^{237}U and ^{241}Am but with widely differing branching ratios. By using the nearby 345.0-keV gamma ray from ^{239}Pu to eliminate some irritating ^{239}Pu interference, the peak areas of the 332.3- and 335.4-keV gamma rays may be accurately determined. An equation involving the measured areas and known relative intensities then yields the $^{241}\text{Am}/^{241}\text{Pu}$ ratio. Just how well this attack will work remains to be seen,

but it has the advantage of using some of the more intense gamma rays in the emitted spectrum.

3.4 Preliminary Results

Work is in progress to determine just how well the procedures and approaches outlined above will work over a broad range of situations. It is already certain that for many situations isotopic information of sufficient accuracy can in fact be obtained on the "arbitrary" sample. The procedures outlined could, of course, be applied to any plutonium sample, but where geometry is controlled and chemical content known better results will no doubt be achieved in many cases by using more specialized procedures which take advantage of the constant geometry and knowledge of the sample.

As an example of the results obtained so far, Table A.2 compares, for a known scrap standard, the mass spectrometric isotopic values and ^{241}Am concentration (determined by alpha counting) with the isotopic distribution and ^{241}Am concentration from gamma-ray spectroscopy. As expected, the most serious discrepancy is in the value for ^{240}Pu which is 6% in error. Although the ^{238}Pu value is 16% different, its concentration is so low that neither value has great accuracy. The americium value differs by ~10% but is based on tabulated data of americium gamma rays which are in some degree suspect. Considerably better results should be expected for the ^{241}Am concentration.

In summary, Table A.2 gives an encouraging example of what might be achieved. Defining the possible precisions and accuracies over the expected range of isotopic distributions awaits further investigations and analysis.

TABLE A.2
COMPARISON OF ISOTOPIC DISTRIBUTION
BY GAMMA-RAY SPECTROSCOPY
WITH ACCEPTED VALUES

Isotope	Accepted Value ^a	Gamma-Ray Value ^a	$\left(\frac{\text{Accepted}}{\text{Gamma-Ray}}\right)^{-1}$
^{238}Pu	0.0116	0.010	0.86
^{239}Pu	94.10	93.75	0.996
^{240}Pu	5.60	5.95	1.06
^{241}Pu	0.271	0.270	0.996
^{241}Am	536	486	0.91

^a All values are given in wt%, except ^{241}Am which is in ppm.

REFERENCES

- A.1 R. Gunnink, "Plutonium Isotopic Measurements by Gamma-Ray Spectrometry," Mound Laboratory report MLM 2177, *Proceedings of the Symposium on the Calorimetric Assay of Plutonium*, Oct. 1973, pp. 45-59.
- A.2 T. D. Reilly, R. B. Walton, and J. L. Parker, "The Enrichment 'Meter'--A Simple Method for Measuring Isotopic Enrichment," Los Alamos Scientific Laboratory report LA-4605-MS (1970), pp. 19-21.

APPENDIX B

DIFFERENTIAL ABSORPTION ATTENUATION CORRECTION FACTOR

The four figures in this appendix illustrate the potential and problems with the differential absorption attenuation correction factor. They show attenuation correction factors at 414 keV or 186 keV as a function of the intensity ratios $I(414)/I(129)$ or $I(186)/I(143)$. The graphs are drawn for varying matrix and high-Z densities (for this discussion, $DM = \text{g/cm}^3$ matrix and $DU = \text{g/cm}^3$ uranium or plutonium). The matrix is assumed to have the attenuation properties of carbon; this is a good assumption for $Z \leq 26$, which includes all combustible materials and the metallic oxides usually found in harder residues such as ash and slag. Uranium and plutonium are assumed to have the same attenuation properties (the worst difference is 5%). The attenuation coefficients used are given in Table B.1. The matrix and the fissile material are assumed to be a homogeneous mixture. Figures B.1 and B.2 pertain to a small scrap can 10-cm diam by 12-cm high. Figures B.3 and B.4 pertain to a large waste drum 58-cm diam by 90-cm high (55-gal drum).

1. Small Scrap Can

Figure B.1 illustrates the variation of $CF(414)$ as a function of $I(414)/I(129)$ for a small scrap can. It illustrates the following points. The iso-fissile lines slope both positive and negative in different regions. This means that the intensity ratio can either increase or decrease as the density and gross attenuation increase. The latter case is interesting and not at all obvious without studying this graph. The intensity ratio is very insensitive to changes in the matrix density, so

TABLE B.1
ATTENUATION COEFFICIENTS (CM^2/G)

Material	Energy (keV)			
	129	143	186	414
Matrix	0.143	0.138	0.128	0.0925
Uranium or Plutonium	3.70	2.87	1.45	0.25

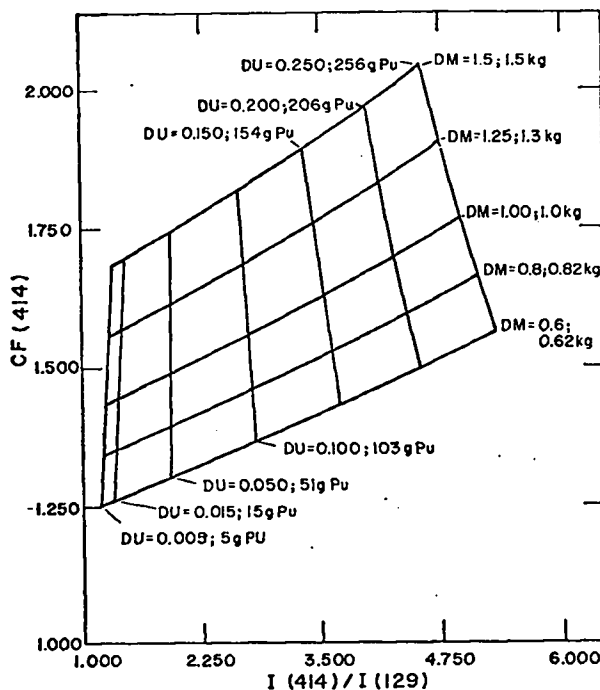

Fig. B.1 Attenuation correction factor at 414 keV as a function of the 414- to 129-keV (^{239}Pu) intensity ratio. The sample container is a 10-cm-diam by 12-cm-high can.

without any further information the intensity ratio cannot give accurate information on the correction factor. Now assume the net weight is known and the cans are all filled to a roughly uniform height. Then the matrix density DM is known, and this plus the intensity ratio define a unique CF . It is then possible also to do an iteration to check on self-absorbing lumps (sample uniformity). The argument is illustrated schematically below.

- (1) Net weight $\rightarrow DM$
- (2) $DM + [I(414)/I(129)] \rightarrow CF(414)$
- (3) $CF \times C(414) \rightarrow \text{g Pu}$
- (4) $\text{g Pu} \rightarrow DU$
- (5) $DU + DM \rightarrow [I(414)/I(129)]''$
- (6) $(I/I)' \approx (I/I)''$

If the two values of $I(414)/I(129)$ agree reasonably well, the assumption of sample uniformity should be good and the assay accurate.

Figure B.2 illustrates the same sample can for a ^{235}U measurement involving the 186- and 143-keV lines. For this case the intensity ratio is rather insensitive to changes in the attenuation correction factor. As CF varies from 2.0 to 4.0, $I(186)/I(143)$ changes only from 1.04 to 1.58. The "lever arm" is the wrong way. In some cases it may still be possible to use this ratio, but the results would probably not be as good. For low-enriched uranium where the enrichment is known and the $^{234\text{m}}\text{Pa}$ daughter is in equilibrium with ^{238}U , this ratio can be used with good results.

2. Large Waste Drum

Figure B.3 illustrates the variation of CF(414) as a function of $I(414)/I(129)$ for a large waste drum (208 liter or 55 gal). The following points are evident. Over the range of fissile loadings below 300 g plutonium, CF(414) is independent of fissile loading; it varies only with matrix density. The "lever arm" is not as good as in the small can, but it should work. As CF(414) varies from 1.17 to 2.50, $I(414)/I(129)$ changes only from 1.09 to 1.42.

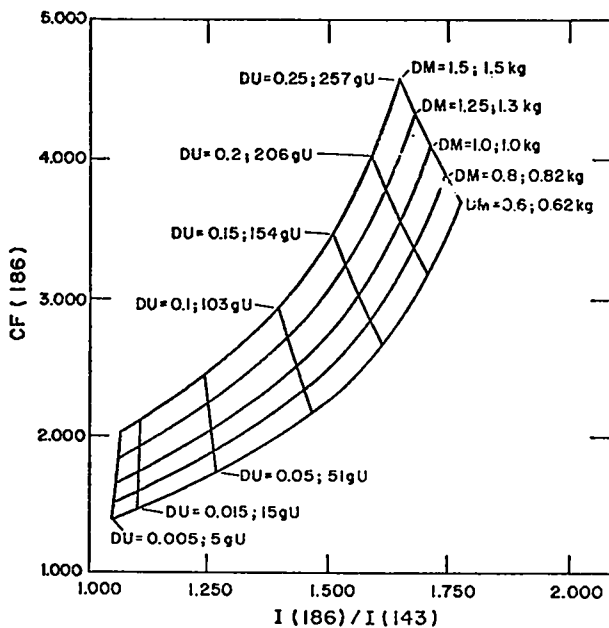

Fig. B.2. Attenuation correction factor at 186 keV as a function of the 186- to 143-keV (^{235}U) intensity ratio. The sample container is a 10-cm-diam by 12-cm-high can.

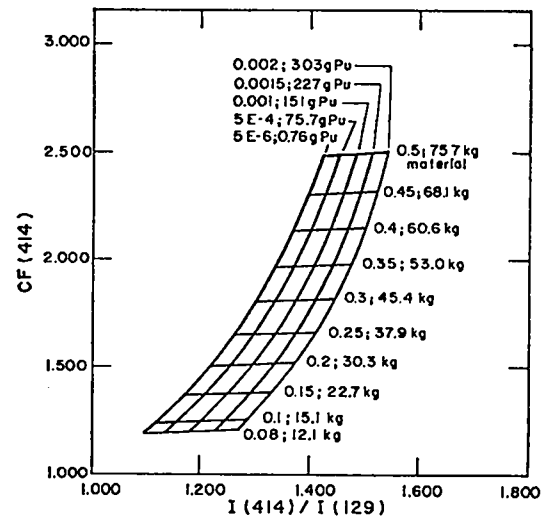

Fig. B.3. Attenuation correction factor at 414 keV as a function of the $I(414)/I(129)$ intensity ratio. The sample container is a 58-cm-diam by 90-cm-high drum (55 gal).

The same comments on net weight, iteration, and uniformity check apply for this case. This graph (for DU = 0) is the case described by Jim Cline in ANCR-1055 (see Ref. 5.1).

Figure B.4 shows the large waste drum for CF(186) vs $I(186)/I(143)$. This ratio will not provide any useful information because there is no "lever arm" at all. Again the 1001- to 186-keV ratio will work well for low-enriched uranium samples which meet the necessary requirement.

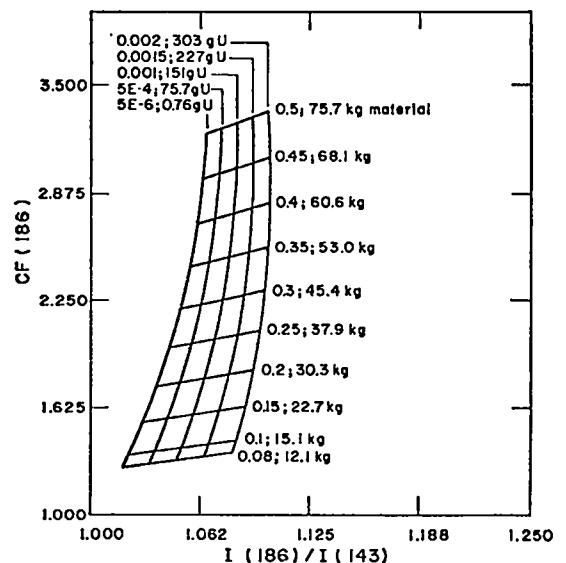

Fig. B.4. Attenuation correction factor at 186 keV as a function of the $I(186)/I(143)$ intensity ratio. The sample container is a 58-cm-diam by 90-cm-high drum (55 gal).

APPENDIX C
 ASSAY EXPRESSIONS FOR A TRANSMISSION-CORRECTED
 SEGMENTED SCAN GAMMA ASSAY MEASUREMENT

The measurement is assumed to involve three gamma-ray lines: one from the isotope of interest in the sample, one from the external transmission source and one from the livetime and pileup correction source taped to the detector. The Compton background is subtracted from each peak using the procedure described in Sec. 3.2 (see Fig. C.1). The net count rate or peak area (A) is given by

$$A = P - \frac{n_p}{2} \left(\frac{B_1}{n_{B_1}} + \frac{B_2}{n_{B_2}} \right) \quad (C.1)$$

where

- A = net counts due to activity of interest,
- P = total peak region count,
- B_1, B_2 = total background window counts,
- n_p = number of channels in peak window,
- n_{B_1}, n_{B_2} = number of channels in background windows.

The uncertainty associated with each peak area [Eq. (C.3)] is determined from the usual definition of standard deviation

$$\sigma_f^2 = \sum_i^n \left(\frac{\partial f}{\partial x_i} \right)^2 \sigma_{x_i}^2 \quad (C.2)$$

where

$$f = f(x_1, x_2, \dots, x_i, \dots, x_n) \quad .$$

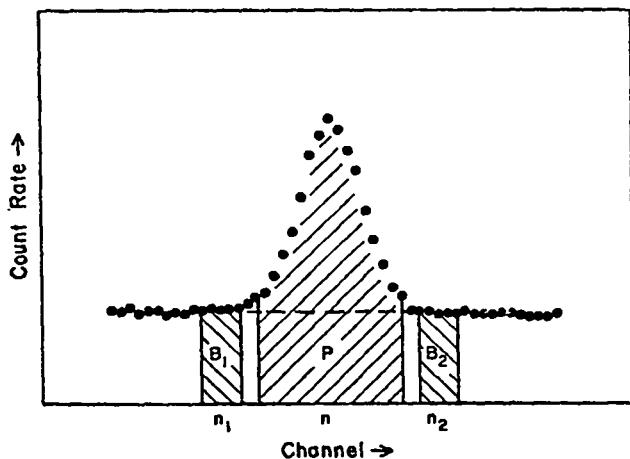

Fig. C.1. Pulse-height spectrum of single photopeak illustrating general procedure for determining photopeak area. The area of interest is above the dashed line which is determined from B_1 and B_2 .

$$\sigma_A^2 = P + \left(\frac{n_p}{2n_{B_1}} \right)^2 B_1 + \left(\frac{n_p}{2n_{B_2}} \right)^2 B_2 \quad (C.3)$$

where

$$\begin{aligned} \sigma_P^2 &= P, \\ \sigma_{B_1}^2 &= B_1, \\ \sigma_{B_2}^2 &= B_2. \end{aligned}$$

Eq. (C.4) gives the expression for the corrected count from the isotope of interest in the sample.

It is this number which is directly proportional to the material quantity of interest.

$$CC = \sum_i CC_i = \sum_i C_i \cdot \frac{LT_o}{LT_i} \cdot CF(T_i') \cdot CF_{can} \quad (C.4)$$

where

CC = total corrected count for sample,

CC_i = corrected count for i^{th} segment,

C_i = sample activity in line of interest from i^{th} segment,

LT_i = activity from livetime source for i^{th} segment,

LT_o = initial activity from livetime source with no sample up,

$$CF(T_i') = \frac{-\beta \ln T_i'}{1 - (T_i')^\beta}$$

β = product of geometric correction factor (~ 0.82 for cylinder) and ratio of mass attenuation coefficients at assay energy and transmission energy,

$$CF_{can} = \frac{1}{\sqrt{T_c}}$$

T_c = transmission of empty can at assay energy,

$$T_i' = \frac{T_i}{T_o} \cdot \frac{LT_o}{LT_i} \cdot \frac{1}{T_c}$$

T_o = initial transmission activity with no sample up.

An approximate expression for the uncertainty in the corrected count (CC_i) is given in Eq. (C.5).

This expression is derived under the following

assumptions. A more complete expression is

$$\sigma_{T_0} = \sigma_{LT_0} = \sigma_{T_c} = 0 ,$$

$$\frac{\partial T_1'}{\partial LT_1} \approx 0 , \text{ i.e. } \sigma(T_1') \approx \sigma(T_1),$$

given in Ref. 7.2. The extra terms given in this reference will usually be insignificant.

$$\begin{aligned} \sigma_{CC_1}^2 &= \left[\frac{LT_0}{LT_1} \cdot CF_1(T_1') \cdot \frac{1}{\sqrt{T_c}} \right]^2 \sigma^2 A(C_1) \\ &+ \left[C_1 \cdot \frac{LT_0}{LT_1^2} \cdot CF_1(T_1') \cdot \frac{1}{\sqrt{T_c}} \right]^2 \sigma^2 A(LT_1) \\ &+ \left[\frac{A^2 \ln T_1'(T_1')^{A-1} + \frac{A}{T_1'} [1 - (T_1')^A]}{[1 - (T_1')^A]^2} \right. \\ &\left. \cdot C_1 \cdot \frac{LT_0}{LT_1} \cdot \frac{1}{\sqrt{T_c}} \right]^2 \sigma^2(T_1) . \end{aligned} \quad (C.5)$$

This calculation will always be on a minicomputer interfaced to the assay system.